

SUHNER[®] MACHINING



ツールホルダー

 OKUMA

Multus

U3000 / U4000 / U5000用
2S / 2S-W



SUHNER
EXPERTS. SINCE 1914.



シューマチック社について

貴方の機械の加工能力を増強します。。。







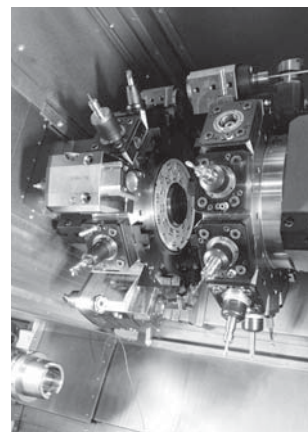
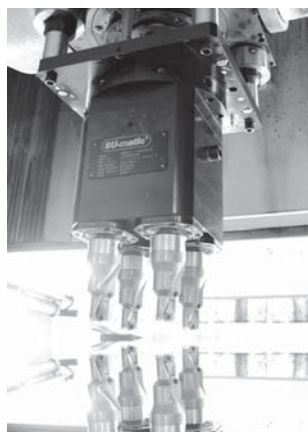
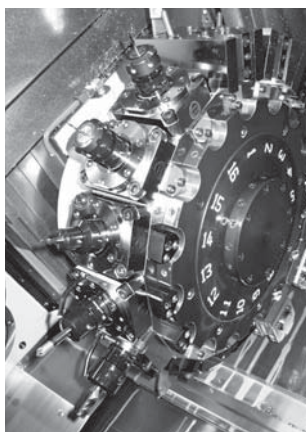

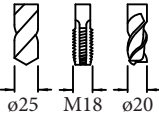

大きな投資をしなくても。。。

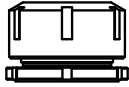
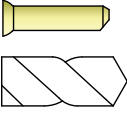
弊社では多軸ヘッド、アングルおよびリボルバーヘッドなど全ての種類のツールホルダーを製造し有名工作機械メーカー殿やOEMメーカーに供給しています。高い性能の装置はDIN規格に準拠し、お客様ご指定のインターフェースに適合しています。標準化された製品の供給は世界的なブランドであるAのアルフレッドシュッテ (ALFRED SCHUTTE,) からWのワールドリッヒ。コブルグ(WALDRICH COBURG)まで拡張しています。

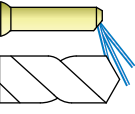
機械メーカーとの新しい製品開発の連携は非常に速い段階から始まります。従って新しい機械が発表された時点で既に実用的な準備はできています。我々は計画、製造、品質管理そしてサービスの全てを自社で行っております。親会社であるスナー(SUHNER)社の世界的な展開により、大きな恩恵を受けています。

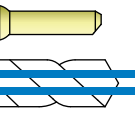

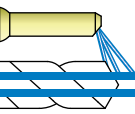







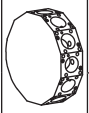



記号の意味

	品名		品名
	これら3つのシンボルはこのユニットで使用可能な最大切削工具径を示しています (ドリル、タップ、ミーリングカッター)。	#	ユニットび部品番号
	内部クーラント型の場合には絶対にドライでは使用しないで下さい。		スピンドル出力インターフェース
	クーラントは使用できません		クーラントタイプ
	外部クーラント		ターニング方向 入力:出力
	内部クーラント		減速比 入力:出力
	内部及び外部クーラント	$n_{2 \max}$	出力側の最大回転数 (RPM)
	本キャプトユニットはサンドビックコロマンの認定を受けています (ISO26623-2)。	$T_{2 \max}$	出力側の最大トルク
		# 	特別付属のレンチの部品番号

索引

キット

	#			在庫品*	ページ
 Multus	14430001990	-	2x  2x  1x  2x  2x  3x 	受注生産	11
	14430001390		2x  2x 	1	11
	14430001400		2x  2x 	1	11

ライブツール(回転工具)

	#			i $n_1 : n_2$	$n_{2 \max}$	$T_{2 \max}$	在庫品*	ページ
	14101002700	ER 32		1 : 1	6'000 min ⁻¹	60 Nm	12	12
	14101002690	ERC 32		1 : 1	6'000 min ⁻¹	60 Nm	6	12
	14101003440	ERAX 32		1 : 1	6'000 min ⁻¹	60 Nm	受注生産	12
	14101000780	PTS-40		1 : 1	6'000 min ⁻¹	60 Nm	受注生産	13
	14101000770	PTS-40		1 : 1	6'000 min ⁻¹	60 Nm	受注生産	13
	14101000760	HSK 40		1 : 1	6'000 min ⁻¹	60 Nm	受注生産	14
	14101000750	HSK 40		1 : 1	6'000 min ⁻¹	60 Nm	受注生産	14













索引

ライブツール(回転工具)

	#			i $n_1 : n_2$	$n_{2 \max}$	$T_{2 \max}$	在庫品*	ページ
	14101000880	ISCAR M16		1 : 1	6'000 min ⁻¹	60 Nm	受注生産	14
	14101000870	ISCAR M16		1 : 1	6'000 min ⁻¹	60 Nm	受注生産	14
	14101001310	ø16		1 : 1	6'000 min ⁻¹	60 Nm	受注生産	15
	14101001060	ø22						
	14101001080	ø27						
	14101001320	ø16		1 : 1	6'000 min ⁻¹	60 Nm	受注生産	15
	14101001100	ø22						
	14101001110	ø27						
	14101001620	ø16		1 : 1	4'000 min ⁻¹	60 Nm	受注生産	16
	14101001070	ø22						
	14101001090	ø27						
	14101001630	ø16		1 : 1	4'000 min ⁻¹	60 Nm	受注生産	16
	14101001120	ø22						
	14101001130	ø27						
	14101002870	ERAX 25		1 : 1	6'000 min ⁻¹	40 Nm	受注生産	17
	14101001461	ERAXC 25		1 : 1	6'000 min ⁻¹	40 Nm	2	17
	14101002990	ERAX 16		1 : 3	18'000 min ⁻¹	6 Nm	受注生産	17
	14101001610	ERAX 20		1 : 1	6'000 min ⁻¹	40 Nm	1	18
	14101002610	ERAX 25		1 : 1	6'000 min ⁻¹	40 Nm	受注生産	18

索引

ライブツール(回転工具)

	#			i $n_1 : n_2$	$n_{2 \max}$	$T_{2 \max}$	在庫品*	ページ
	14101001640	ERAX 16		1 : 1	6'000 min ⁻¹	35 Nm	受注生産	19
	14800003660	ER 32		1 : 1	6'000 min ⁻¹	60 Nm	2	19
	14800003670	ERC 32		1 : 1	6'000 min ⁻¹	60 Nm	2	19
	14801001230	ER 32		1 : 1	6'000 min ⁻¹	60 Nm	受注生産	20
	14800003160	ø10 ø13 ø16 ø22		1 : 1	6'000 min ⁻¹	25 Nm	受注生産	20
	14800002280	ø13 ø16 ø22		2 : 1	3'000 min ⁻¹	50 Nm	受注生産	21













索引

静止ツール

	#			$n_1^i : n_2$	$n_{2 \max}$	$T_{2 \max}$	在庫品*	ページ
	14910001640	∅40		-	-	-	受注生産	22
	14910001650	∅40		-	-	-	4	22
	14910001660	□25x25		-	-	-	受注生産	23
	14910001670	□25x25		-	-	-	4	23
	14910001680	□25x25		-	-	-	2	24
	14910001691	4x32		-	-	-	6	25
	14910000581	4x32		-	-	-	3	25
	14910002071	4x32		-	-	-	受注生産	25
	14910003810	4x32		-	-	-	受注生産	25

SU-matic® Capto® ライブツール(回転工具)

	#			$\frac{i}{n_1 : n_2}$	$n_{2 \max}$	$T_{2 \max}$	在庫品*	ページ
	14101003250	Capto C4		1 : 1	6'000 min ⁻¹	60 Nm	5	26
	14101003160	Capto C5		1 : 1	6'000 min ⁻¹	60 Nm	受注生産	26
	14800003680	Capto C4		1 : 1	6'000 min ⁻¹	60 Nm	受注生産	27
	14801001440	Capto C4		1 : 1	6'000 min ⁻¹	60 Nm	受注生産	27







索引

SU-matic® Capto® 静止ツール

	#			i $n_1 : n_2$	$n_{2 \max}$	$T_{2 \max}$	在庫品*	ページ
	14910002660	Capto C4		-	-	-	受注生産	28
	14910003880	Capto C5		-	-	-	受注生産	28
	14910002460	Capto C6		-	-	-	受注生産	29
	14910002670	Capto C4		-	-	-	8	29
	14910003870	Capto C5		-	-	-	受注生産	30
	14910001960	Capto C4		-	-	-	受注生産	30
	14910002680	Capto C4		-	-	-	受注生産	31
	14910003190	Capto C5		-	-	-	受注生産	31
	14910002450	Capto C6		-	-	-	受注生産	32
	14910002690	Capto C4		-	-	-	受注生産	32

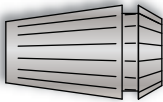
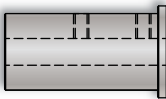
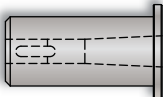
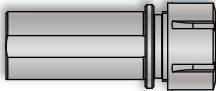
付属品

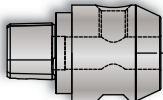
	品名		在庫品*	ページ
	ターレット用プラグ(栓)	-	20	33
	高圧クーラントパイプ	-	受注生産	33
	コレット	ER 11 - ER 50	受注生産	34
	ø32 / ø40	ø6 - ø25	受注生産	35
	ø32 / ø40	MT 1 - MT 4	受注生産	35
	ø32 / ø40	ER 25 - ER 32	受注生産	35
	Capto C3 / C4	ER 16 - ER 25	受注生産	36
	Capto C3 / C4	ø6 - ø16	受注生産	36
	Capto C4	ø16 - ø27	受注生産	36

Multus キット

Multus U3000 / U4000 / U5000 • 2S / 2S-W • V12

SU-matic®

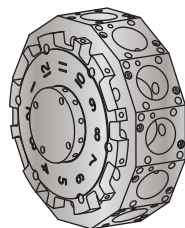

品名		静止ツールキット	ライブツール(回転工具)キット	
#	Type	2S / 2S-W		
	#	14430001990	14430001390	14430001400
14910001660		2		
14910001670		2		
14910001680		1		
14910001640		2		
14910001650		2		
14430000140		3		
14101002700			2	
14800003660			2	
14101002690				2
14800003670				2

ライブツール(回転工具)

LOKUMA

Lathe Linear Unit • LLU 60-1 R

SU-matic®

Machine Types	Genos L300 (BMT) M / MW / MY / MYW	Genos L3000 (BMT) M / MW / MY	LB2000 EX M / MW / MY	LB3000 EX M / MW / MY / MYW	LU3000 EX M / MW / MY	Multus U3000 / U4000 / U5000 2S / 2S-W
---------------	---------------------------------------	----------------------------------	--------------------------	--------------------------------	--------------------------	-------------------------------------------

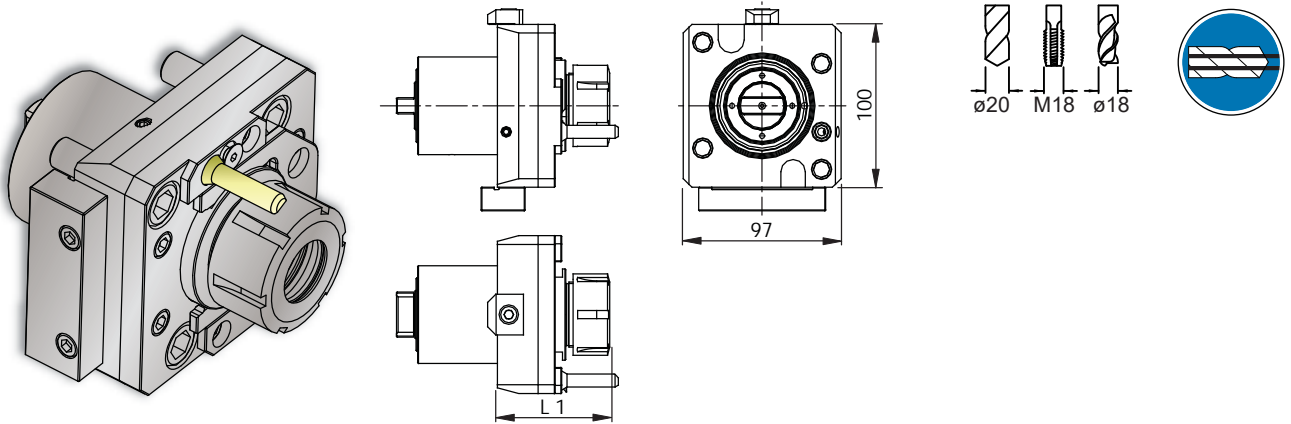

#			$n_1 : n_2$	i $n_1 : n_2$	$n_{2 \max}$	$T_{2 \max}$	L1	#
14101002700	ER 32	100 bar		1 : 1	6'000 min ⁻¹	60 Nm	69	14430100040
14101002690	ERC 32	70 bar		1 : 1	6'000 min ⁻¹	60 Nm	74	14430100040

Lathe Linear Unit • LLU 60-1 R

SU-matic®

Machine Types	Genos L300 (BMT) MY / MW / MYW	Genos L3000 (BMT) MY / MW	LB2000 EX M / MW / MY	LB3000 EX M / MW / MY / MYW	LU3000 EX M / MW / MY	Multus U3000 / U4000 / U5000 2S / 2S-W
---------------	-----------------------------------	------------------------------	--------------------------	--------------------------------	--------------------------	-------------------------------------------

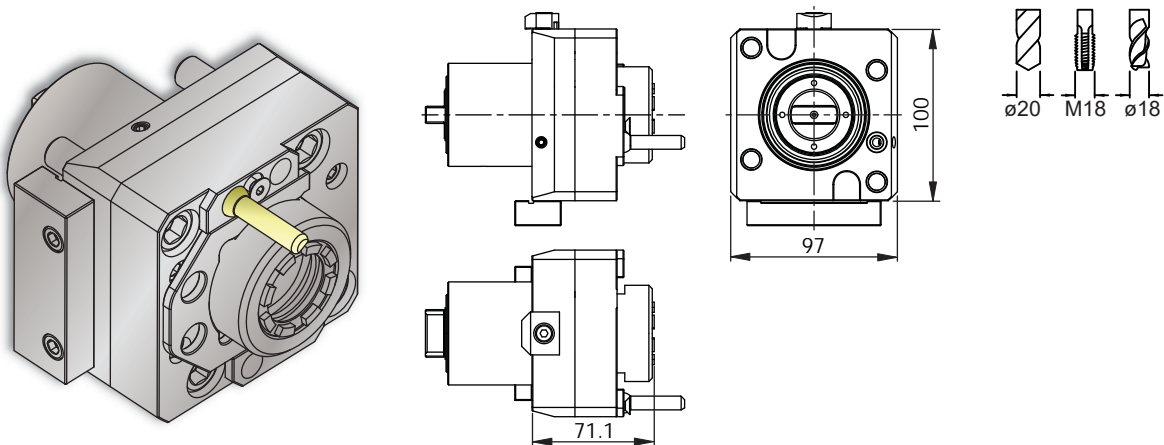

#			$n_1 : n_2$	i $n_1 : n_2$	$n_{2 \max}$	$T_{2 \max}$	#
14101003440	ERAX 32	100 bar		1 : 1	6'000 min ⁻¹	60 Nm	3020820006

ライブツール(回転工具)

LOKUMA

Lathe Linear Unit • LLU 60-1 R

SU-matic®

Machine Types	Genos L300 (BMT) M / MW / MY / MYW	Genos L3000 (BMT) M / MW / MY	LB2000 EX M / MW / MY	LB3000 EX M / MW / MY / MYW	LU3000 EX M / MW / MY	Multus U3000 / U4000 / U5000 2S / 2S-W
---------------	---------------------------------------	----------------------------------	--------------------------	--------------------------------	--------------------------	-------------------------------------------

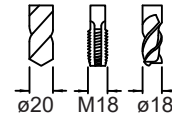
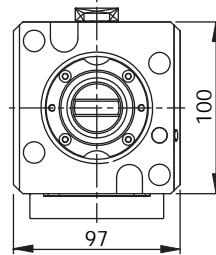
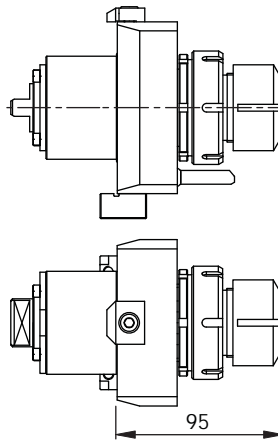
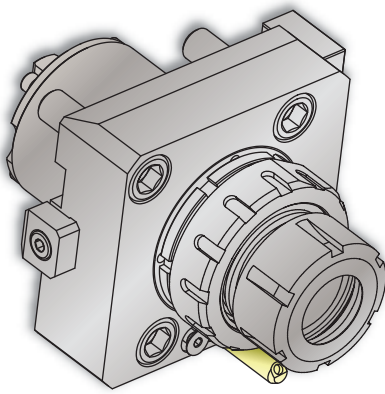

#			$n_1 : n_2$	i $n_1 : n_2$	$n_{2 \max}$	$T_{2 \max}$	#
14101000780	PTS-40	100 bar		1 : 1	6'000 min ⁻¹	60 Nm	14430100050
14101000770	PTS-40	70 bar		1 : 1	6'000 min ⁻¹	60 Nm	14430100050

ライブツール(回転工具)

LOKUMA

Lathe Linear Unit • LLU 60-1 R

SU-matic®

Machine Types	Genos L300 (BMT) M / MW / MY / MYW	Genos L3000 (BMT) M / MW / MY	LB2000 EX M / MW / MY	LB3000 EX M / MW / MY / MYW	LU3000 EX M / MW / MY	Multus U3000 / U4000 / U5000 2S / 2S-W
---------------	---------------------------------------	----------------------------------	--------------------------	--------------------------------	--------------------------	-------------------------------------------

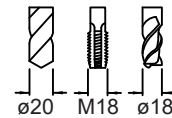
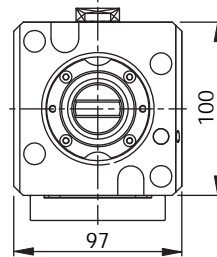
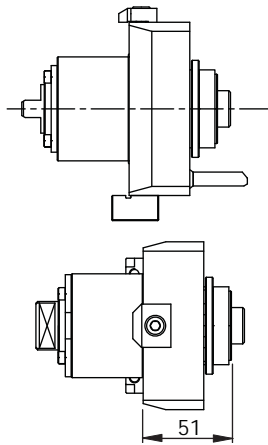
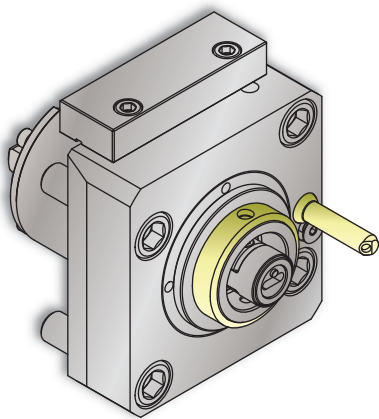

#			$n_1 : n_2$	i $n_1 : n_2$	$n_2 \text{ max}$	$T_2 \text{ max}$	#
14101000760	HSK 40	100 bar		1:1	6'000 min ⁻¹	60 Nm	-
14101000750	HSK 40	70 bar		1:1	6'000 min ⁻¹	60 Nm	-

Lathe Linear Unit • LLU 60-1 R

SU-matic®

Machine Types	Genos L300 (BMT) M / MW / MY / MYW	Genos L3000 (BMT) M / MW / MY	LB2000 EX M / MW / MY	LB3000 EX M / MW / MY / MYW	LU3000 EX M / MW / MY	Multus U3000 / U4000 / U5000 2S / 2S-W
---------------	---------------------------------------	----------------------------------	--------------------------	--------------------------------	--------------------------	-------------------------------------------

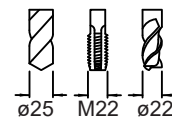
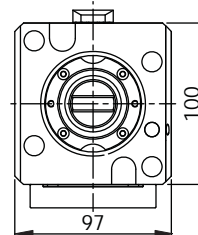
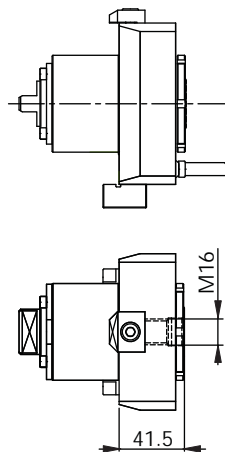
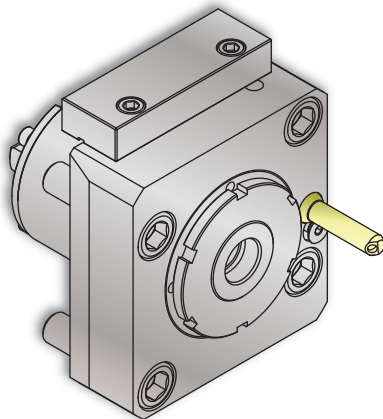

#			$n_1 : n_2$	i $n_1 : n_2$	$n_2 \text{ max}$	$T_2 \text{ max}$	#
14101000880	ISCAR M16	100 bar		1:1	6'000 min ⁻¹	60 Nm	14430100050
14101000870	ISCAR M16	70 bar		1:1	6'000 min ⁻¹	60 Nm	14430100050

ライブツール(回転工具)

LOKUMA

Lathe Linear Unit • LLU 60-1 R

SU-matic®

Machine Types	Genos L300 (BMT) M / MW / MY / MYW	Genos L3000 (BMT) M / MW / MY	LB2000 EX M / MW / MY	LB3000 EX M / MW / MY / MYW	LU3000 EX M / MW / MY	Multus U3000 / U4000 / U5000 2S / 2S-W
---------------	---------------------------------------	----------------------------------	--------------------------	--------------------------------	--------------------------	-------------------------------------------

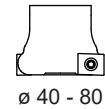
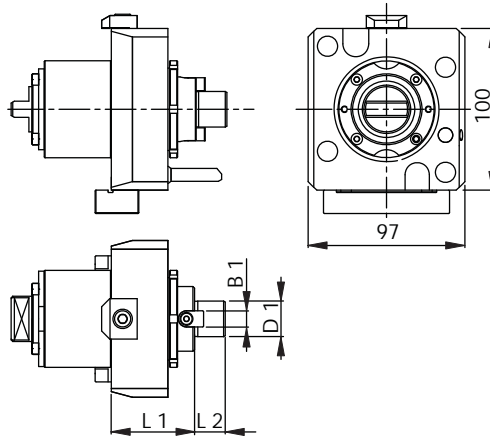
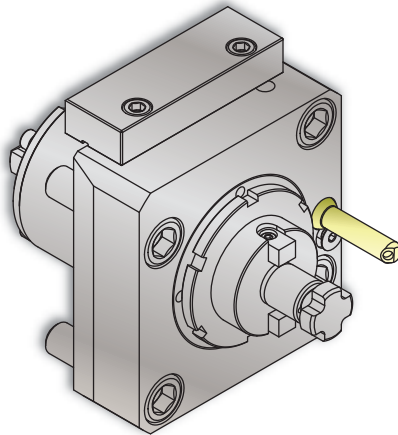

#			$n_1 : n_2$	i $n_1 : n_2$	$n_{2 \max}$	$T_{2 \max}$	L1	L2	B1	D1	#	
14101001310	ø16		100 bar		1 : 1	6'000 min ⁻¹	60 Nm	52.5	17	8	ø16	14430100210
14101001320	ø16		70 bar		1 : 1	6'000 min ⁻¹	60 Nm	52.5	17	8	ø16	14430100210
14101001060	ø22		100 bar		1 : 1	6'000 min ⁻¹	60 Nm	52.5	19	10	ø22	14430100130
14101001100	ø22		70 bar		1 : 1	6'000 min ⁻¹	60 Nm	52.5	19	10	ø22	14430100130
14101001080	ø27		100 bar		1 : 1	6'000 min ⁻¹	60 Nm	51.5	21	12	ø27	14430100100
14101001110	ø27		70 bar		1 : 1	6'000 min ⁻¹	60 Nm	51.5	21	12	ø27	14430100100

これらのユニットにはアンギュラー
コンタクトベアリグを使用

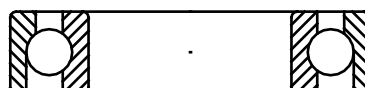

ライブツール(回転工具)

LOKUMA

Lathe Linear Unit • LLU 60-1 R

SU-matic®

Machine Types	Genos L300 (BMT) M / MW / MY / MYW	Genos L3000 (BMT) M / MW / MY	LB2000 EX M / MW / MY	LB3000 EX M / MW / MY / MYW	LU3000 EX M / MW / MY	Multus U3000 / U4000 / U5000 2S / 2S-W
---------------	---------------------------------------	----------------------------------	--------------------------	--------------------------------	--------------------------	-------------------------------------------

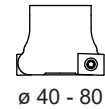
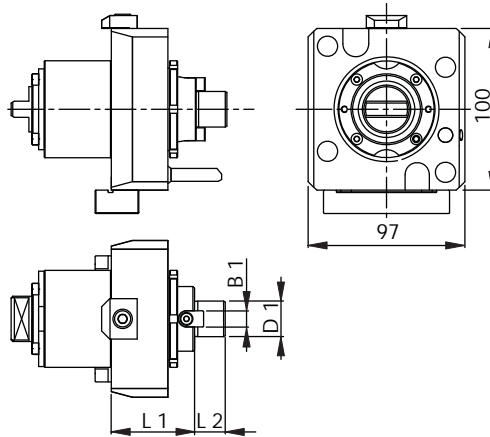
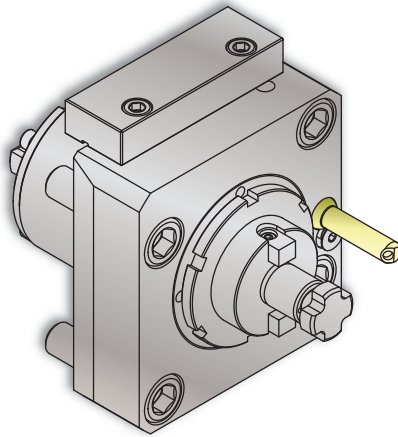

#			$n_1 : n_2$	$i_{n_1 : n_2}$	$n_{2 \max}$	$T_{2 \max}$	L1	L2	B1	D1	#
14101001620	ø16			1 : 1	4'000 min ⁻¹	60 Nm	55	17	8	ø16	14430100210
14101001630	ø16			1 : 1	4'000 min ⁻¹	60 Nm	55	17	8	ø16	14430100210
14101001070	ø22			1 : 1	4'000 min ⁻¹	60 Nm	55	19	10	ø22	14430100130
14101001120	ø22			1 : 1	4'000 min ⁻¹	60 Nm	55	19	10	ø22	14430100130
14101001090	ø27			1 : 1	4'000 min ⁻¹	60 Nm	55	21	12	ø27	14430100100
14101001130	ø27			1 : 1	4'000 min ⁻¹	60 Nm	55	21	12	ø27	14430100100

これらのユニットにはテーパローラーベアリグを使用

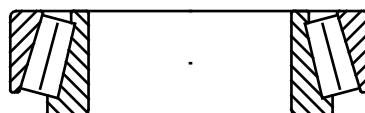

ライブツール(回転工具)

LOKUMA

Lathe Linear Unit Offset • LLUO 40-1 R

SU-matic®

Machine Types	Genos L300 (BMT) M / MW / MY / MYW	Genos L3000 (BMT) M / MW / MY	LB2000 EX M / MW / MY	LB3000 EX M / MW / MY / MYW	LU3000 EX M / MW / MY	Multus U3000 / U4000 / U5000 2S / 2S-W
---------------	---------------------------------------	----------------------------------	--------------------------	--------------------------------	--------------------------	-------------------------------------------

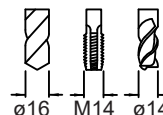
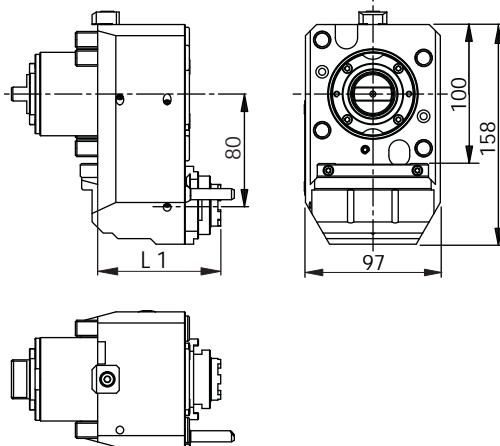
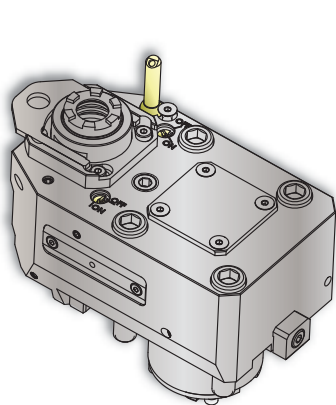

#			$n_1 : n_2$	i $n_1 : n_2$	$n_{2 \max}$	$T_{2 \max}$	L 1	#
14101002870	ERAX 25	100 bar		1 : 1	6'000 min ⁻¹	40 Nm	83.5	14430101470
14101001461	ERAXC 25	100 bar		1 : 1	6'000 min ⁻¹	40 Nm	88.5	14430101470

Lathe Linear Unit Offset (High Speed) • LLUO 6-1 R

SU-matic®

Machine Types	Genos L300 (BMT) M / MW / MY / MYW	Genos L3000 (BMT) M / MW / MY	LB2000 EX M / MW / MY	LB3000 EX M / MW / MY / MYW	LU3000 EX M / MW / MY	Multus U3000 / U4000 / U5000 2S / 2S-W
---------------	---------------------------------------	----------------------------------	--------------------------	--------------------------------	--------------------------	-------------------------------------------

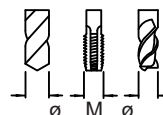
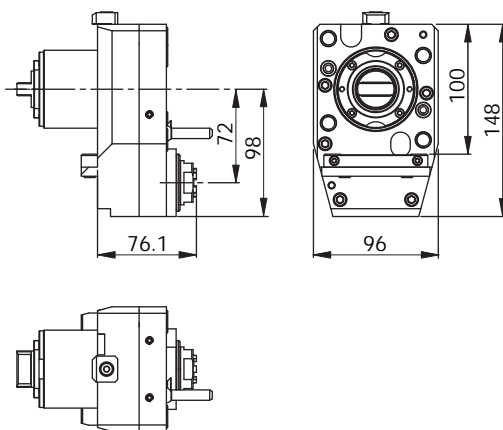
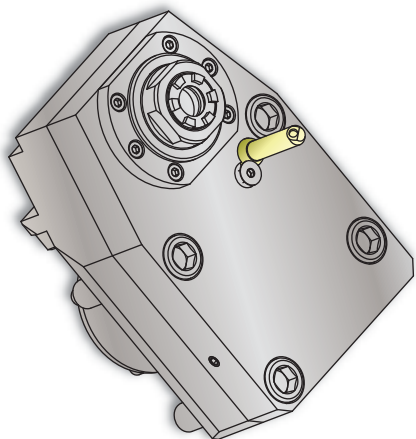

#			$n_1 : n_2$	i $n_1 : n_2$	$n_{2 \max}$	$T_{2 \max}$	#
14101002990	ERAX 16	100 bar		1 : 3	18'000 min ⁻¹ *	6 Nm	14430100990

* 全サイクル時間の20%の場合(オーバーヒートのリスク)

ライブツール(回転工具)

LOKUMA

Lathe Linear Unit Offset • LLUO 40-2 R

SU-matic®

Machine Types	Genos L300 (BMT) MY / MYW	Genos L3000 (BMT) MY	LB2000 EX MY	LB3000 EX MY / MYW	LU3000 EX MY	Multus U3000 / U4000 / U5000 2S / 2S-W	
#			$n_1 : n_2$	i $n_1 : n_2$	$n_{2 \max}$	$T_{2 \max}$	#
14101001610	ERAX 20	100 bar		1 : 1	6'000 min ⁻¹	40 Nm	14430100660

Lathe Linear Unit Offset • LLUO 40-2 R

SU-matic®

Machine Types	Genos L300 (BMT) MY / MYW	Genos L3000 (BMT) MY	LB2000 EX MY	LB3000 EX MY / MYW	LU3000 EX MY	Multus U3000 / U4000 / U5000 2S / 2S-W	
#			$n_1 : n_2$	i $n_1 : n_2$	$n_{2 \max}$	$T_{2 \max}$	#
14101002610	ERAX 25	100 bar		1 : 1	6'000 min ⁻¹	40 Nm	14430101470

ライブツール(回転工具)

LOKUMA

Lathe Linear Unit Offset • LLUO 35-4 R

SU-matic®

Machine Types	Genos L300 (BMT) MYW	LB3000 EX MYW	Multus U3000 / U4000 / U5000 2S-W
---------------	-------------------------	------------------	--------------------------------------

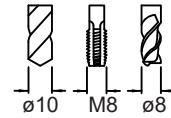
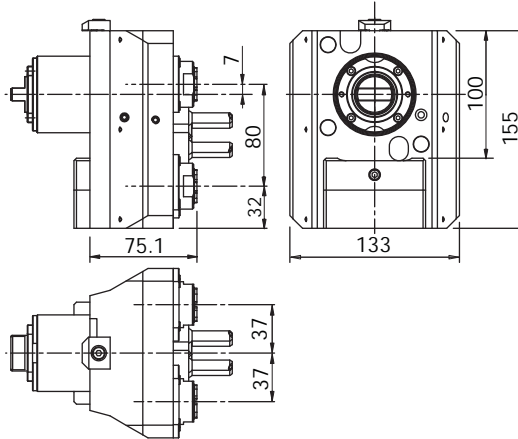
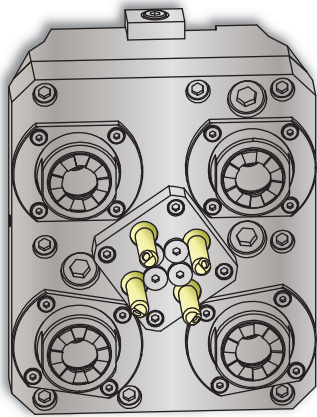

#			$n_1 : n_2$	i $n_1 : n_2$	$n_{2 \max}$	$T_{2 \max}$	#
14101001640	ERAX 16	100 bar		1:1	6'000 min ⁻¹	35 Nm	14430100740

Lathe Angular Unit • LAU 60-1 A

SU-matic®

Machine Types	Multus U3000 / U4000 / U5000 2S / 2S-W
---------------	-------------------------------------------

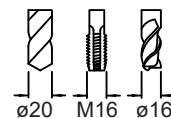
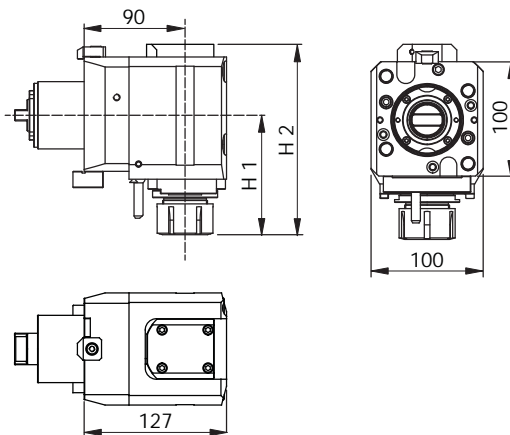
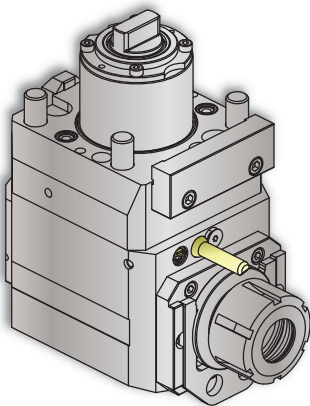

#			$n_1 : n_2$	i $n_1 : n_2$	$n_{2 \max}$	$T_{2 \max}$	H1	H2	#
14800003660	ER 32	100 bar		1:1	6'000 min ⁻¹	60 Nm	101	152.5	14430101500
14800003670	ERC 32	100 bar		1:1	6'000 min ⁻¹	60 Nm	106	172	14430101500

ライブツール(回転工具)

LOKUMA

Lathe Angular Unit Twin • LAUT 60-1+1 A

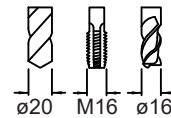
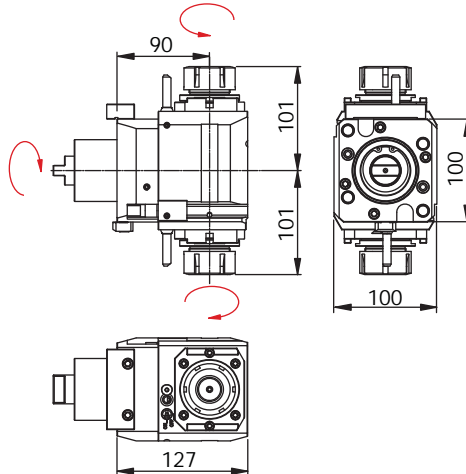
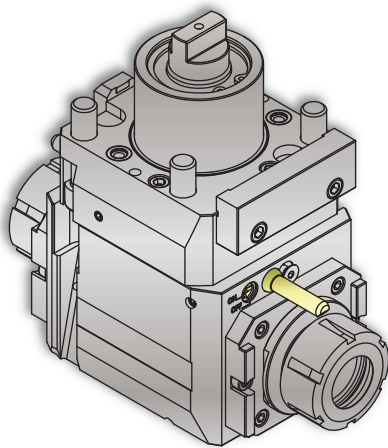
SU-matic®
Machine Types Multus U3000 / U4000 / U5000
2S-W

#			$n_1 : n_2$	i $n_1 : n_2$	$n_2 \text{ max}$	$T_2 \text{ max}$	#
14801001230	ER 32	100 bar	-	1 : 1	6'000 min ⁻¹	60 Nm	14430100040

Lathe Angular Unit Milling • LAUM 25-1 A

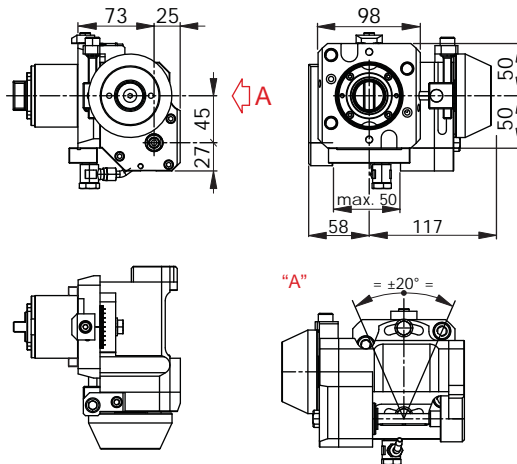
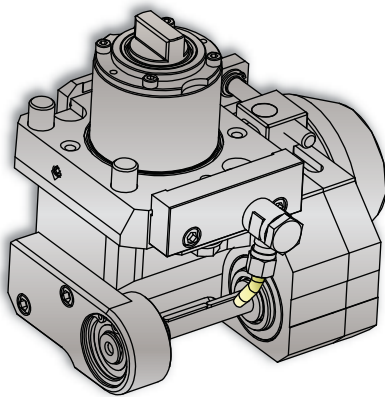
SU-matic®
Machine Types Genos L300 (BMT) M / MW / MY / MYW Genos L3000 (BMT) M / MW / MY LB2000 EX M / MW / MY LB3000 EX M / MW / MY / MYW LU3000 EX M / MW / MY Multus U3000 / U4000 / U5000 2S / 2S-W

#	+			$n_1 : n_2$	i $n_1 : n_2$	$n_2 \text{ max}$	$T_2 \text{ max}$	#
14800003160	+ 14420001150 →	ø10	100 bar		1 : 1	6'000 min ⁻¹	25 Nm	14430101100
	+ 14420001160 →	ø13	100 bar		1 : 1	6'000 min ⁻¹	25 Nm	14430101100
	+ 14420001170 →	ø16	100 bar		1 : 1	6'000 min ⁻¹	25 Nm	14430101100
	+ 14420001190 →	ø22	100 bar		1 : 1	6'000 min ⁻¹	25 Nm	14430101100

ライブツール(回転工具)

LOKUMA

Lathe Angular Unit Milling • LAUM 50-1 A

SU-matic®

Machine Types	Genos L300 (BMT) M / MW / MY / MYW	Genos L3000 (BMT) M / MW / MY	LB2000 EX M / MW / MY	LB3000 EX M / MW / MY / MYW	LU3000 EX M / MW / MY	Multus U3000 / U4000 / U5000 2S / 2S-W
---------------	---------------------------------------	----------------------------------	--------------------------	--------------------------------	--------------------------	-------------------------------------------

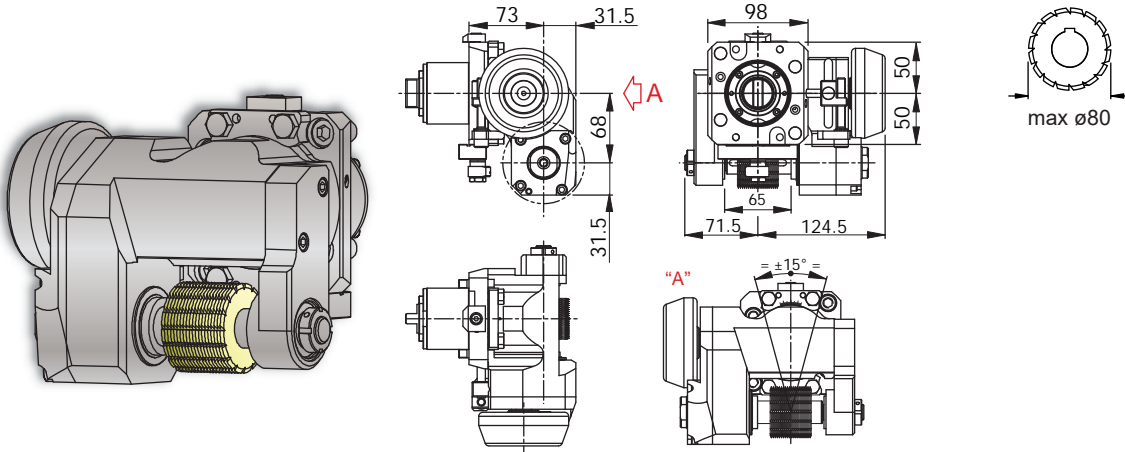

#	+			$n_1 : n_2$	i $n_1 : n_2$	$n_{2 \max}$	$T_{2 \max}$	#	
14800002280	+ 14420001240 →	ø13		100 bar		2 : 1	3'000 min ⁻¹	50 Nm	14430100460
	+ 14420000430 →	ø16		100 bar		2 : 1	3'000 min ⁻¹	50 Nm	14430100460
	+ 14420000440 →	ø22		100 bar		2 : 1	3'000 min ⁻¹	50 Nm	14430100460







静止ツール

Lathe Angular Static • LAS 40-1 A

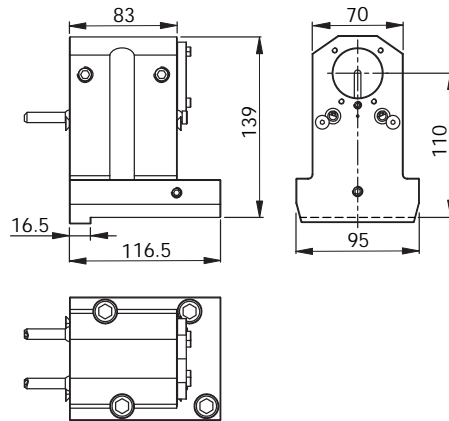
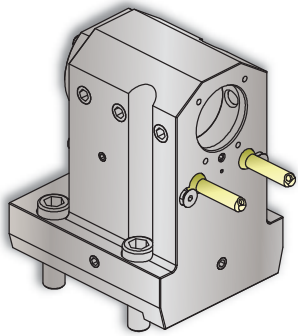
SU-matic®

Machine Types LT3000 EX Multus U3000 / U4000 / U5000
M / MY 2S / 2S-W







#				# 
14910001640	ø40	 100 bar		-

Lathe Angular Static Twin • LAST 40-1+1 A

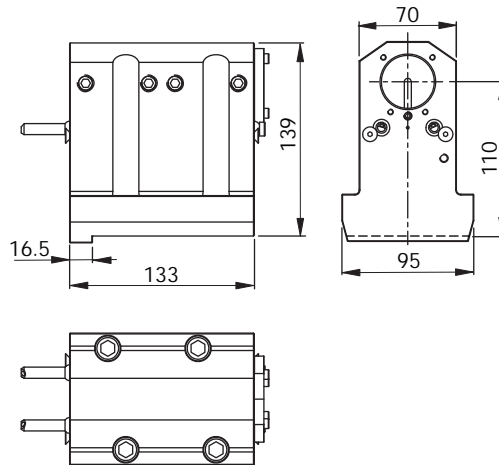
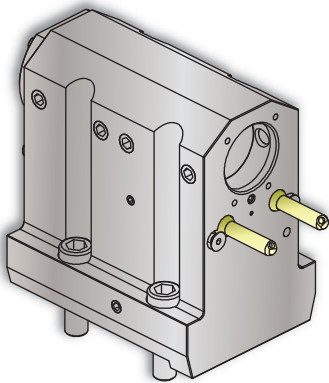
SU-matic®

Machine Types LT3000 EX Multus U3000 / U4000 / U5000
M / MY 2S / 2S-W



#				# 
14910001650	ø40	 100 bar		-

静止ツール





LOKUMA

Lathe Linear Static • LLS 25-1 R

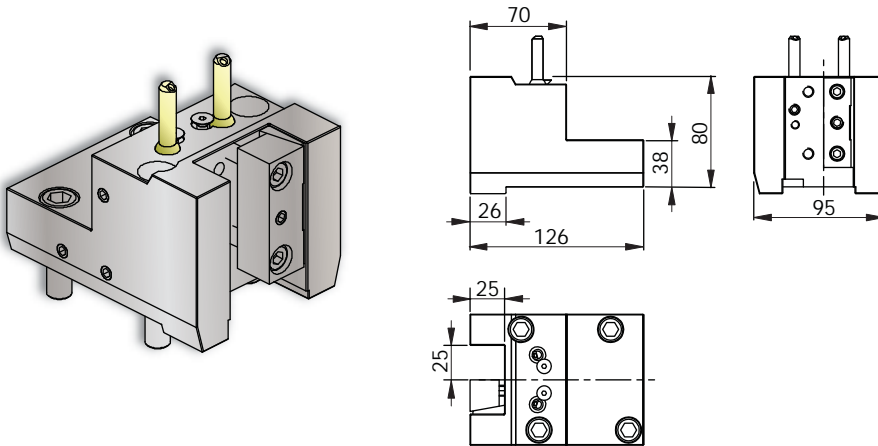
SU-matic®

Machine Types LT3000 EX Multus U3000 / U4000 / U5000
M / MY 2S / 2S-W







#				# 
14910001660	□25x25	 100 bar		-

Lathe Linear Static Twin • LLST 25-1+1 R

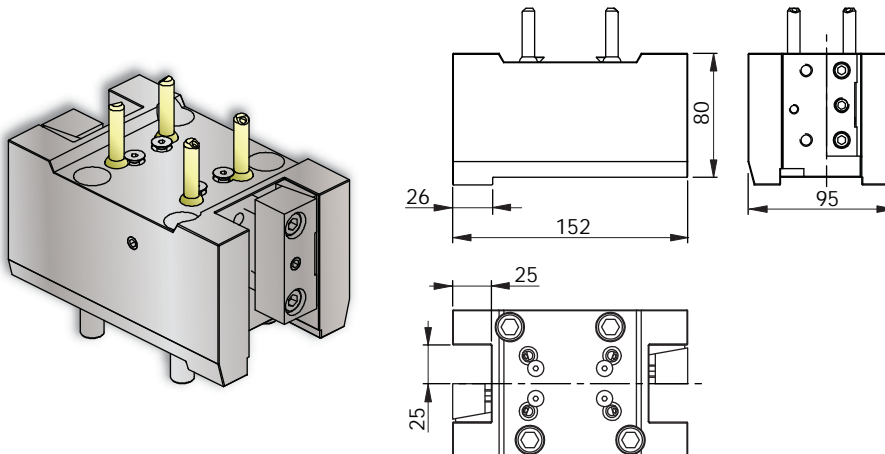
SU-matic®

Machine Types LT3000 EX Multus U3000 / U4000 / U5000
M / MY 2S-W



#				# 
14910001670	□25x25	 100 bar		-

静止ツール

LOKUMA

Lathe Angular Static Twin • LAST 25-1+1 A

SU-matic®

Machine Types	LT3000 EX	Multus U3000 / U4000 / U5000
	M / MY	2S-W

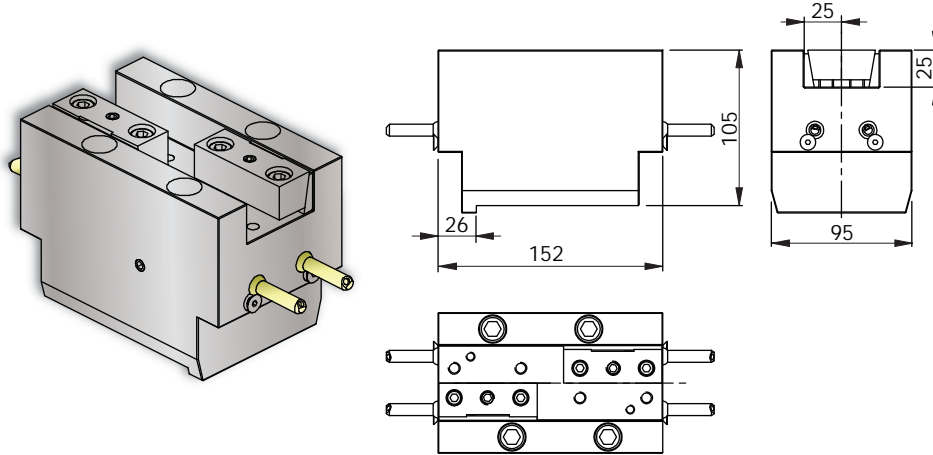

#				#
14910001680	□25x25	 100 bar		-

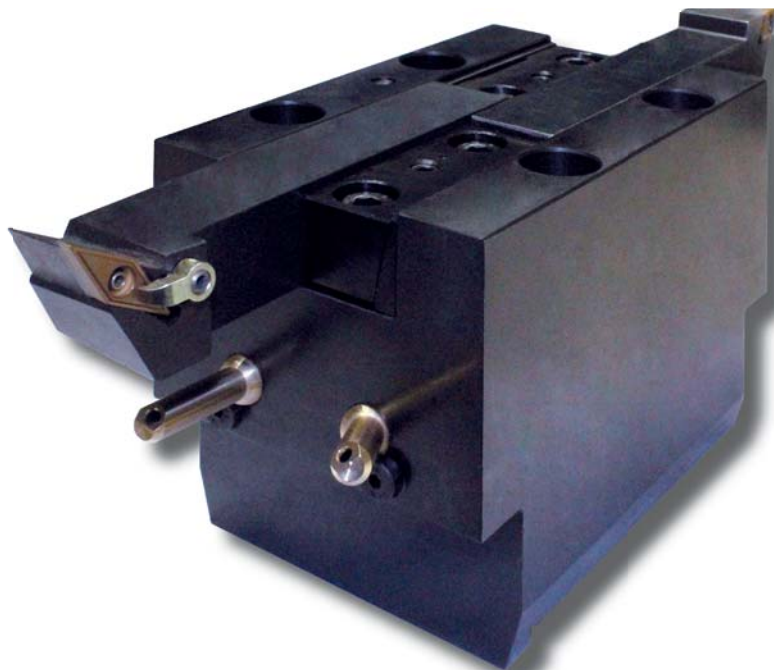

静止ツール





LOKUMA

Lathe Linear Static • LLS 32-1 R • Basic

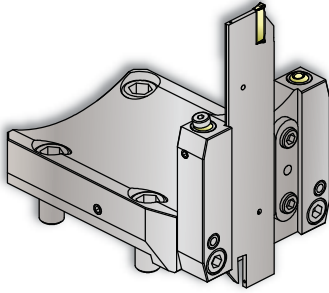
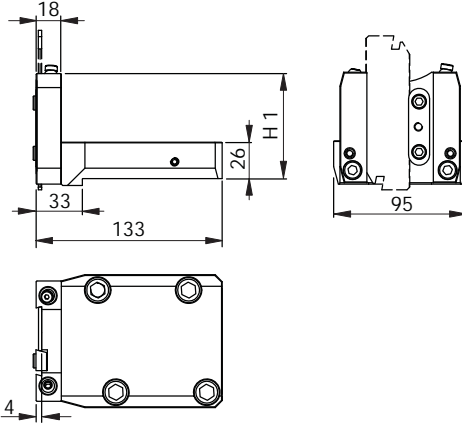
SU-matic®

Machine Types	Genos L300/L3000(BMT)	LB2000 EX	LB3000 EX	LU3000 EX	LT3000 EX	Multus U3000 / U4000 / U5000
	M / MW / MY / MYW	M / MW / MY	M / MW / MY / MYW	M / MW / MY	M / MY	2S / 2S-W







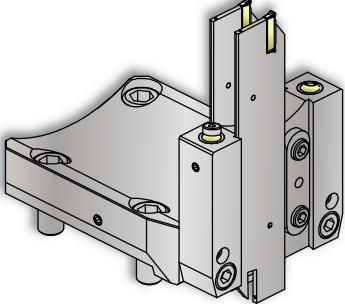
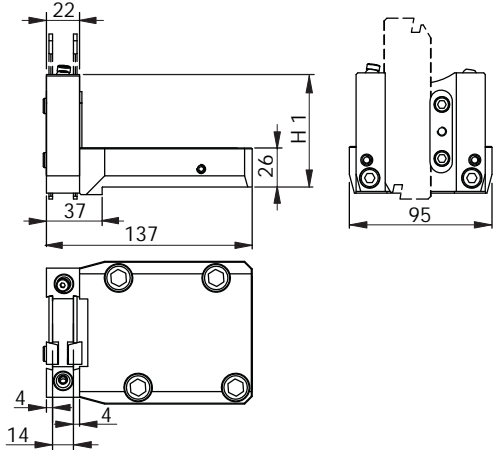

#			H1	# 
14910001691	4x32	 100 bar	75	-
14910000581	4x32	 100 bar	115	-

Lathe Linear Static • LLS 32-2 R • Premium

SU-matic®

Machine Types	Genos L300/L3000(BMT)	LB2000 EX	LB3000 EX	LU3000 EX	LT3000 EX	Multus U3000 / U4000 / U5000
	M / MW / MY / MYW	M / MW / MY	M / MW / MY / MYW	M / MW / MY	M / MY	2S / 2S-W

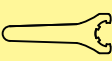
#			H1	# 
14910002071	4x32	 100 bar	75	-
14910003810	4x32	 100 bar	100	-

CAPTO® ライブツール(回転工具)

LOKUMA

Lathe Linear Unit • LLU 60-1 R C4

SU-matic®

Machine Types	Genos L300 (BMT) M / MW / MY / MYW	Genos L3000 (BMT) M / MW / MY	LB2000 EX M / MW / MY	LB3000 EX M / MW / MY / MYW	LU3000 EX M / MW / MY	Multus U3000 / U4000 / U5000 2S / 2S-W
---------------	---------------------------------------	----------------------------------	--------------------------	--------------------------------	--------------------------	-------------------------------------------

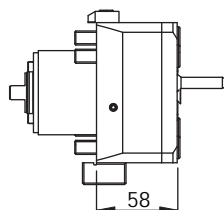
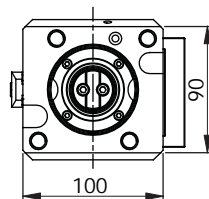
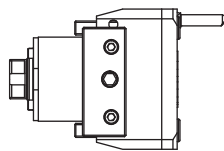
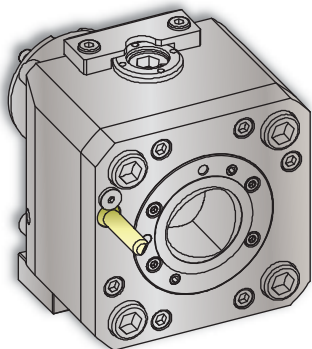

#			$n_1 : n_2$	i $n_1 : n_2$	$n_{2 \max}$	$T_{2 \max}$	#
14101003250	Capto C4	70 bar		1:1	6'000 min ⁻¹	60 Nm	14430100980

Lathe Linear Unit • LLU 60-1 R C5

SU-matic®

Machine Types	Genos L300 (BMT) M / MY / MW / MYW	Genos L3000 (BMT) M / MW / MY	LB3000 EX M / MW / MY / MYW	LU3000 EX M / MW / MY	Multus U3000 / U4000 / U5000 2S / 2S-W
---------------	---------------------------------------	----------------------------------	--------------------------------	--------------------------	-------------------------------------------

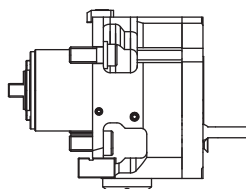
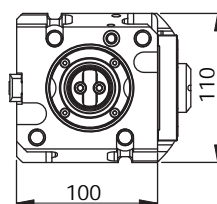
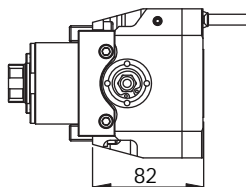
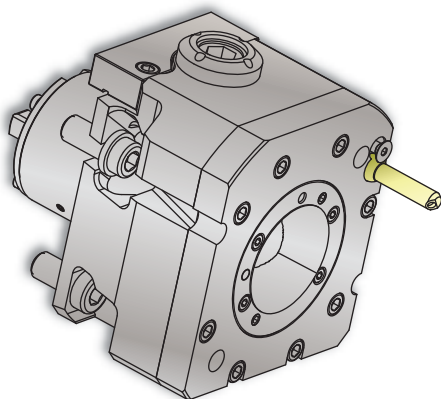

ターレットの旋回は制限されます！

#			$n_1 : n_2$	i $n_1 : n_2$	$n_{2 \max}$	$T_{2 \max}$	#
14101003160	Capto C5	70 bar		1:1	6'000 min ⁻¹	60 Nm	14430100980

CAPTO®

ライブツール(回転工具)

LOKUMA

Lathe Angular Unit • LAU 60-1 A C4

SU-matic®

Machine Types Multus U3000 / U4000 / U5000
2S / 2S-W

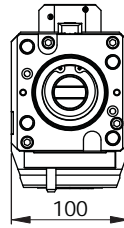
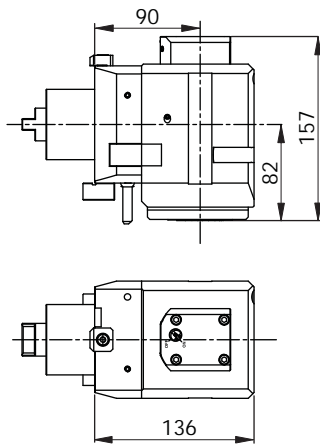
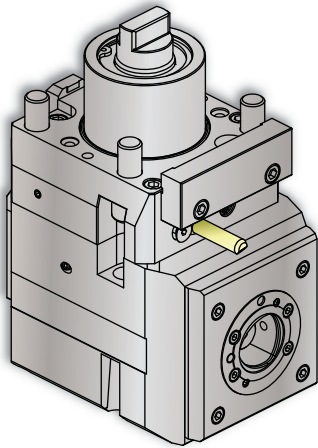

#			$n_1 : n_2$	i $n_1 : n_2$	$n_{2 \max}$	$T_{2 \max}$	#
14800003680	Capto C4	100 bar		1:1	6'000 min ⁻¹	60 Nm	14430100980

Lathe Angular Unit Twin • LAU 60-1+1 A C4

SU-matic®

Machine Types Multus U3000 / U4000 / U5000
2S / 2S-W

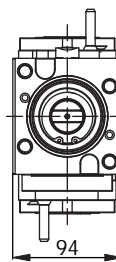
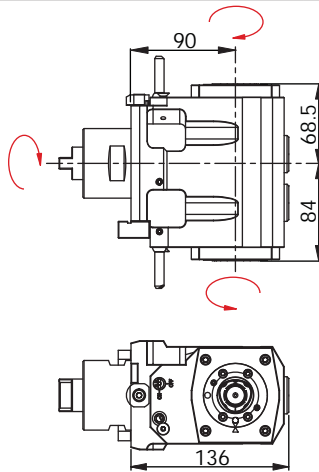
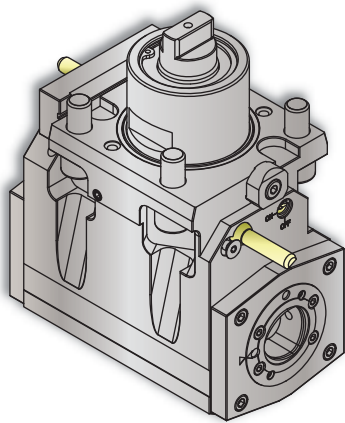

#			$n_1 : n_2$	i $n_1 : n_2$	$n_{2 \max}$	$T_{2 \max}$	#
14801001440	Capto C4	100 bar	-	1:1	6'000 min ⁻¹	60 Nm	14430100980

CAPTO® 静止ツール

LOKUMA

Lathe Linear Static • LLS C4-1 R

SU-matic®

Machine Types	LT3000 EX M / MY	Multus U3000 / U4000 / U5000 2S / 2S-W
----------------------	---------------------	-------------------------------------------

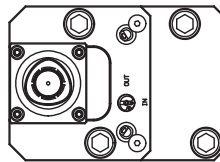
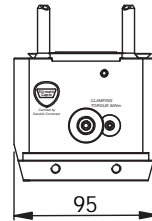
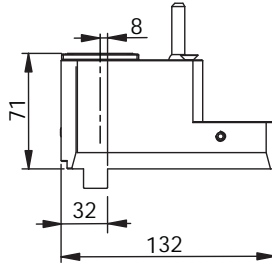
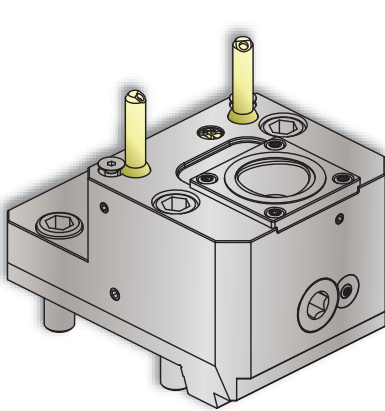

#



#



14910002660

Capto C4



100 bar

14430100980

Lathe Linear Static • LLS C5-1 R

SU-matic®

Machine Types	LT3000 EX M / MY	Multus U3000 / U4000 / U5000 2S / 2S-W
----------------------	---------------------	-------------------------------------------

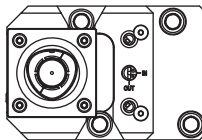
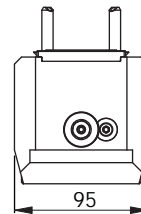
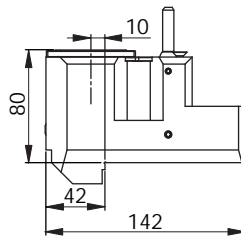
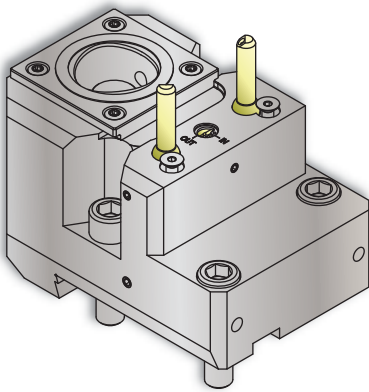

#



#



14910003880

Capto C5



100 bar

14430100980

CAPTO®

静止ツール

LOKUMA

Lathe Linear Static Offset • LLSO C6-1 R

SU-matic®

Machine Types LT3000 EX Multus U3000 / U4000 / U5000
M / MY 2S / 2S-W

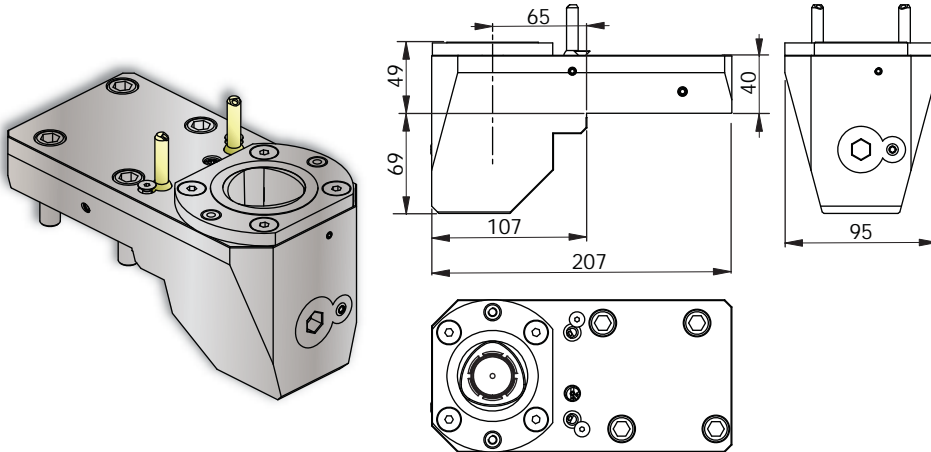

#



#



14910002460

Capto C6



100 bar

14430100980

Lathe Linear Static Twin • LLST C4-1+1 R

SU-matic®

Machine Types LT3000 EX Multus U3000 / U4000 / U5000
M / MY 2S-W

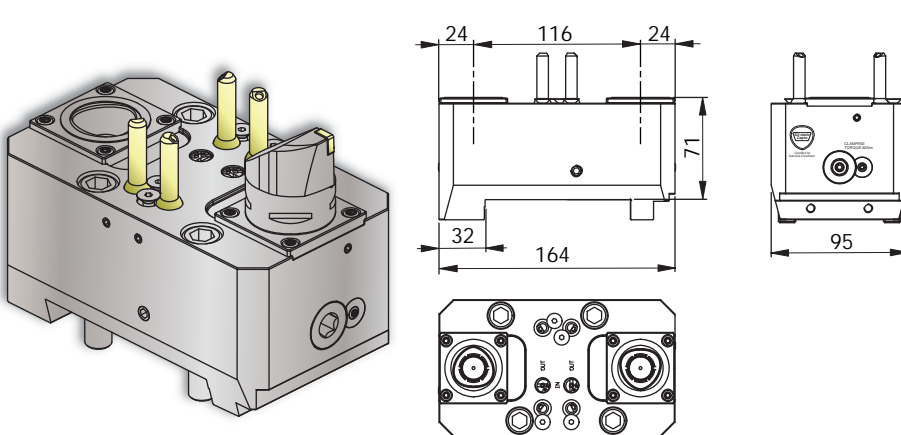

#



#



14910002670

Capto C4



100 bar

14430100980

CAPTO® 静止ツール

LOKUMA

Lathe Linear Static Twin • LLST C5-1+1 R

SU-matic®

Machine Types	LT3000 EX M / MY	Multus U3000 / U4000 / U5000 2S / 2S-W
----------------------	---------------------	-------------------------------------------

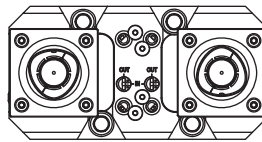
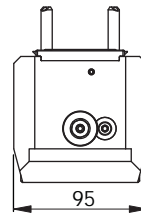
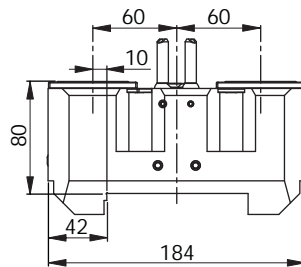
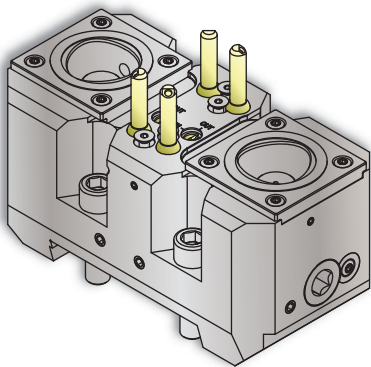

#				#
14910003870	Capto C5	100 bar		14430100980

Lathe Angular Static • LAS C4-1 A

SU-matic®

Machine Types	LT3000 EX M / MY	Multus U3000 / U4000 / U5000 2S / 2S-W
----------------------	---------------------	-------------------------------------------

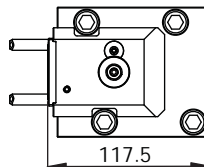
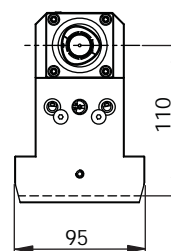
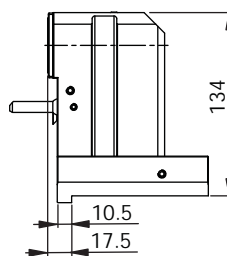
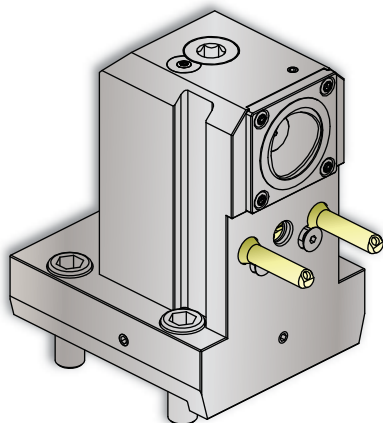

#				#
14910001960	Capto C4	100 bar		14430100980

CAPTO®

静止ツール

LOKUMA

Lathe Angular Static Offset • LASO C4-1 A

SU-matic®

Machine Types | LT3000 EX | Multus U3000 / U4000 / U5000
M / MY | 2S / 2S-W

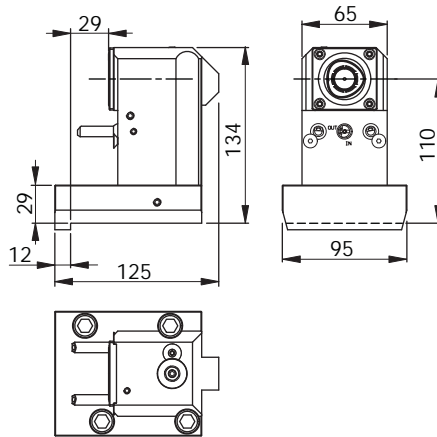
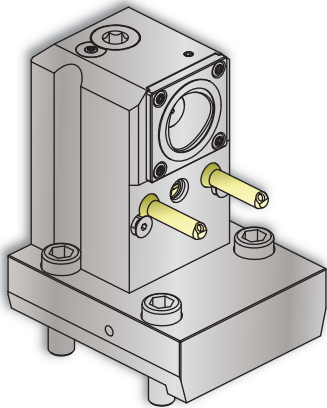

#				#
14910002680	Capto C4	100 bar		14430100980

Lathe Angular Static Offset • LASO C5-1 A

SU-matic®

Machine Types | LT3000 EX | Multus U3000 / U4000 / U5000
M / MY | 2S / 2S-W

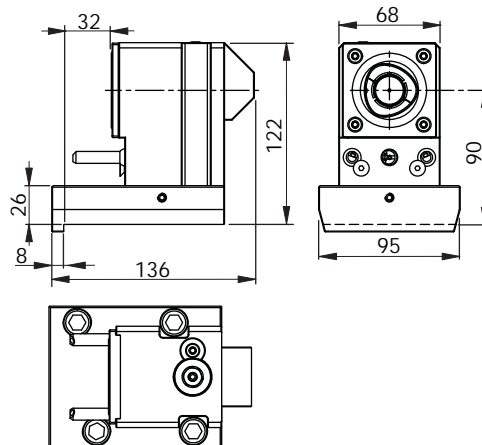
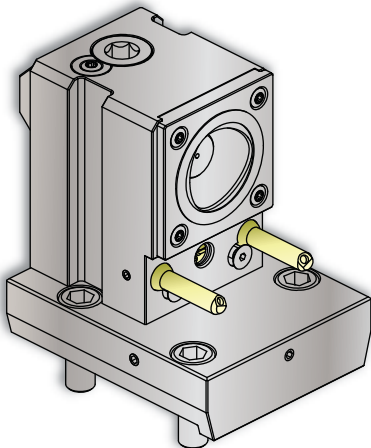

#				#
14910003190	Capto C5	100 bar		14430100980

CAPTO® 静止ツール

LOKUMA

Lathe Angular Static • LAS C6-1 A

SU-matic®

Machine Types	LT3000 EX M / MY	Multus U3000 / U4000 / U5000 2S / 2S-W
----------------------	---------------------	-------------------------------------------

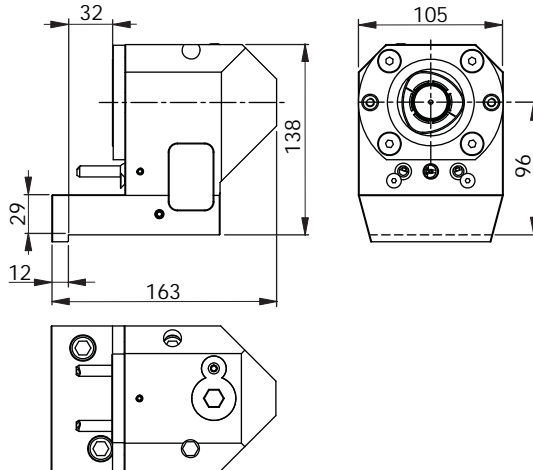
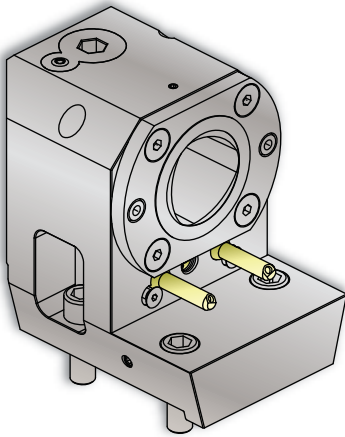

#				#
14910002450	Capto C6	100 bar		14430100980

Lathe Angular Static Twin • LAST C4-1+1 A

SU-matic®

Machine Types	LT3000 EX M / MY	Multus U3000 / U4000 / U5000 2S-W
----------------------	---------------------	--------------------------------------

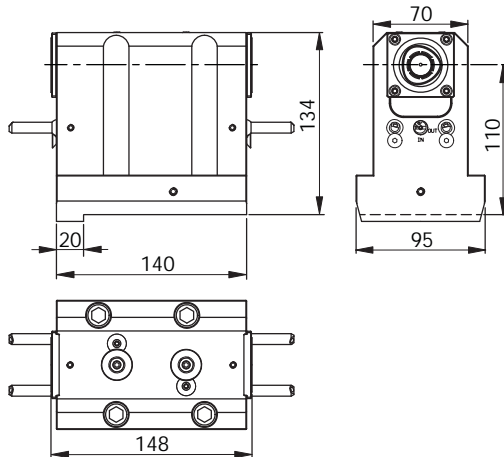
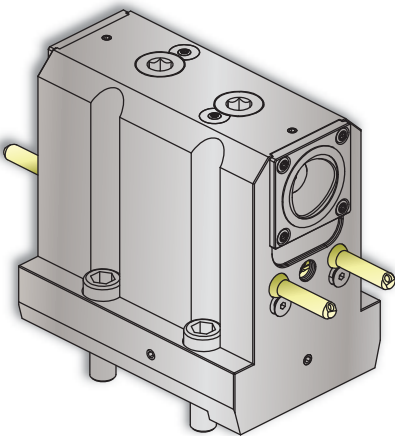

#				#
14910002690	Capto C4	100 bar		14430100980

付属品

ターレット用プラグ(栓)

SU-matic®

Machine
Types

Genos L300

LB2000 EX

LB3000 EX

LT3000 EX

LU3000 EX

Multus

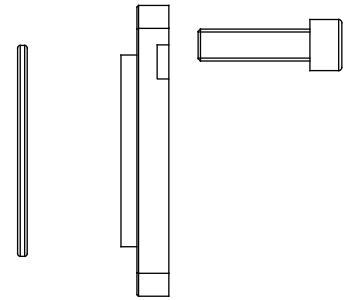
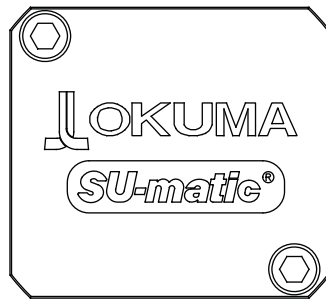
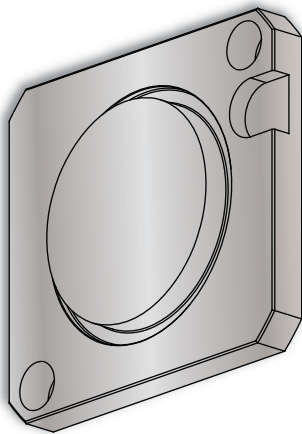

#

14430000140

高圧クーラントパイプ

SU-matic®

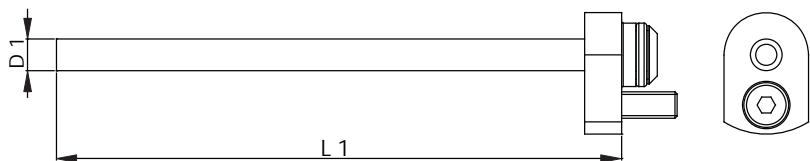
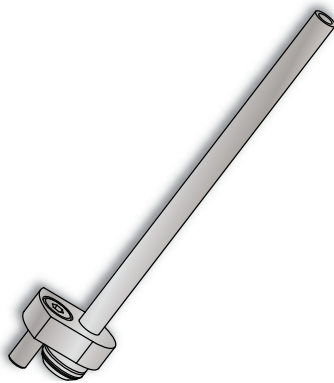

#

L1

D1

14430000750

107

6

付属品

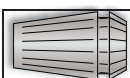

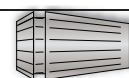

SU-matic® コレット

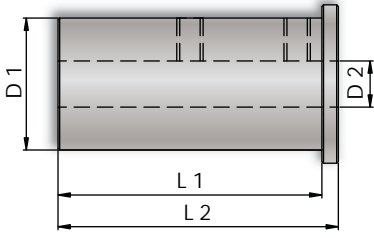

	ER 11	ER 16	ER 20	ER 25	ER 32	ER 40	ER 50
ø 1.00 - 0.50	3900110010	3900160010	3900200010	3900250010	-	-	-
ø 2.00 - 1.00	3900110020	3900160020	3900200020	3900250020	3900320020	-	-
ø 3.00 - 2.00	3900110030	3900160030	3900200030	3900250030	3900320030	3900400030	-
ø 4.00 - 3.00	3900110040	3900160040	3900200040	3900250040	3900320040	3900400040	-
ø 5.00 - 4.00	3900110050	3900160050	3900200050	3900250050	3900320050	3900400050	3900500060
ø 6.00 - 5.00	3900110060	3900160060	3900200060	3900250060	3900320060	3900400060	-
ø 7.00 - 6.00	3900110070	3900160070	3900200070	3900250070	3900320070	3900400070	3900500080
ø 8.00 - 7.00	-	3900160080	3900200080	3900250080	3900320080	3900400080	-
ø 9.00 - 8.00	-	3900160090	3900200090	3900250090	3900320090	3900400090	3900500100
ø 10.00 - 9.00	-	3900160100	3900200100	3900250100	3900320100	3900400100	-
ø 11.00 - 10.00	-	-	3900200110	3900250110	3900320110	3900400110	3900500120
ø 12.00 - 11.00	-	-	3900200120	3900250120	3900320120	3900400120	-
ø 13.00 - 12.00	-	-	3900200130	3900250130	3900320130	3900400130	3900500140
ø 14.00 - 13.00	-	-	-	3900250140	3900320140	3900400140	-
ø 15.00 - 14.00	-	-	-	3900250150	3900320150	3900400150	3900500160
ø 16.00 - 15.00	-	-	-	3900250160	3900320160	3900400160	-
ø 17.00 - 16.00	-	-	-	3900250170	3900320170	3900400170	3900500180
ø 18.00 - 17.00	-	-	-	-	3900320180	3900400180	-
ø 19.00 - 18.00	-	-	-	-	3900320190	3900400190	3900500200
ø 20.00 - 19.00	-	-	-	-	3900320200	3900400200	-
ø 21.00 - 20.00	-	-	-	-	3900320210	3900400210	3900500220
ø 22.00 - 21.00	-	-	-	-	3900320220	3900400220	-
ø 23.00 - 22.00	-	-	-	-	-	3900400230	3900500240
ø 24.00 - 23.00	-	-	-	-	-	3900400240	-
ø 25.00 - 24.00	-	-	-	-	-	3900400250	3900500260
ø 26.00 - 25.00	-	-	-	-	-	3900400260	-
ø 27.00 - 26.00	-	-	-	-	-	3900400270	3900500280
ø 28.00 - 27.00	-	-	-	-	-	3900400280	-
ø 29.00 - 28.00	-	-	-	-	-	3900400290	3900500300
ø 30.00 - 29.00	-	-	-	-	-	3900400300	-
ø 32.00 - 30.00	-	-	-	-	-	-	3900500320
ø 34.00 - 32.00	-	-	-	-	-	-	3900500340
ø 36.00 - 34.00	-	-	-	-	-	-	3900500360

付属品

リダクションスリーブ (円筒形)	#		D 1	D 2	L1	L2
	3001404010	Ø 32 x 6 mm	32	6	70	75
	3001404011	Ø 32 x 8 mm	32	8	70	75
	3001404012	Ø 32 x 10 mm	32	10	70	75
	3001404013	Ø 32 x 12 mm	32	12	70	75
	3001404014	Ø 32 x 14 mm	32	14	70	75
	3001404015	Ø 32 x 16 mm	32	16	70	75
	3001404016	Ø 32 x 18 mm	32	18	70	75
	3001404017	Ø 32 x 20 mm	32	20	70	75
	3001405004	Ø 32 x 25 mm	32	25	70	75
	3001404018	Ø 40 x 6 mm	40	6	80	85
	3001404019	Ø 40 x 8 mm	40	8	80	85
	3001404020	Ø 40 x 10 mm	40	10	80	85
	3001404021	Ø 40 x 12 mm	40	12	80	85
	3001404022	Ø 40 x 14 mm	40	14	80	85
	3001404023	Ø 40 x 16 mm	40	16	80	85
	3001404024	Ø 40 x 18 mm	40	18	80	85
	3001404025	Ø 40 x 20 mm	40	20	80	85
	3001404026	Ø 40 x 25 mm	40	25	80	85
	3001405005	Ø 40 x 32 mm	40	32	80	85

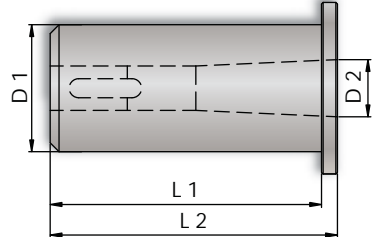
リダクションスリーブ (モールステーパ)	#		D 1	D 2	L1	L2
	3001403006	Ø 32 x MT 1	32	MT 1	85	90
	3001403007	Ø 32 x MT 2	32	MT 2	85	90
	3001403008	Ø 32 x MT 3	32	MT 3	95	100
	3001403009	Ø 40 x MT 2	40	MT 2	105	110
	3001403010	Ø 40 x MT 3	40	MT 3	105	110
	3001403011	Ø 40 x MT 4	40	MT 4	120	125

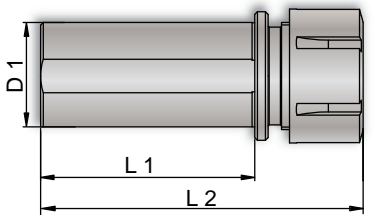
コレットツールホルダー	#		L1	L2	D1	-
	14420000870	Ø 32 x ER 25	70	107.5	32	-
	14420000810	Ø 32 x ER 32	113	153.5	32	-
	14420000880	Ø 40 x ER 32	70	107.5	40	-

付属品

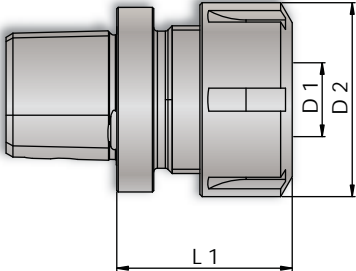
Capto	#		D 1	D 2	L1	-
	14420001030	C3 x ER 16	ER 16	ø28	35	-
	14420001040	C3 x ER 20	ER 20	ø34	36	-
	14420001080	C4 x ER 16	ER 16	ø28	35	-
	14420001090	C4 x ER 25	ER 25	ø42	38	-

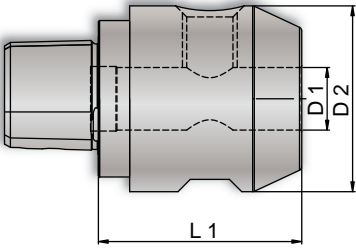
Capto	#		D 1	D 2	L1	-
	14420001000	C3 x Ø 6mm	ø6	ø24	43	-
	14420001010	C3 x Ø 10mm	ø10	ø34.5	47	-
	14420001020	C3 x Ø 12mm	ø12	ø41.5	52	-
	144200010XX	C4 x Ø 6mm	ø6	ø24.5	40	-
	14420001050	C4 x Ø 10mm	ø10	ø34.5	47	-
	14420001060	C4 x Ø 12mm	ø12	ø41.5	49	-
	14420001070	C4 x Ø 16mm	ø16	ø47.5	52	-

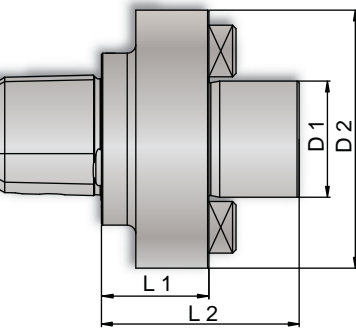
Capto	#		D 1	D 2	L1	L2
	144200010XX	C4 x Ø 16mm	ø16	ø36	20	37
	144200010XX	C4 x Ø 22mm	ø22	ø48	20	39
	144200010XX	C4 x Ø 27mm	ø27	ø60	25	46

インターフェース

LOKUMA

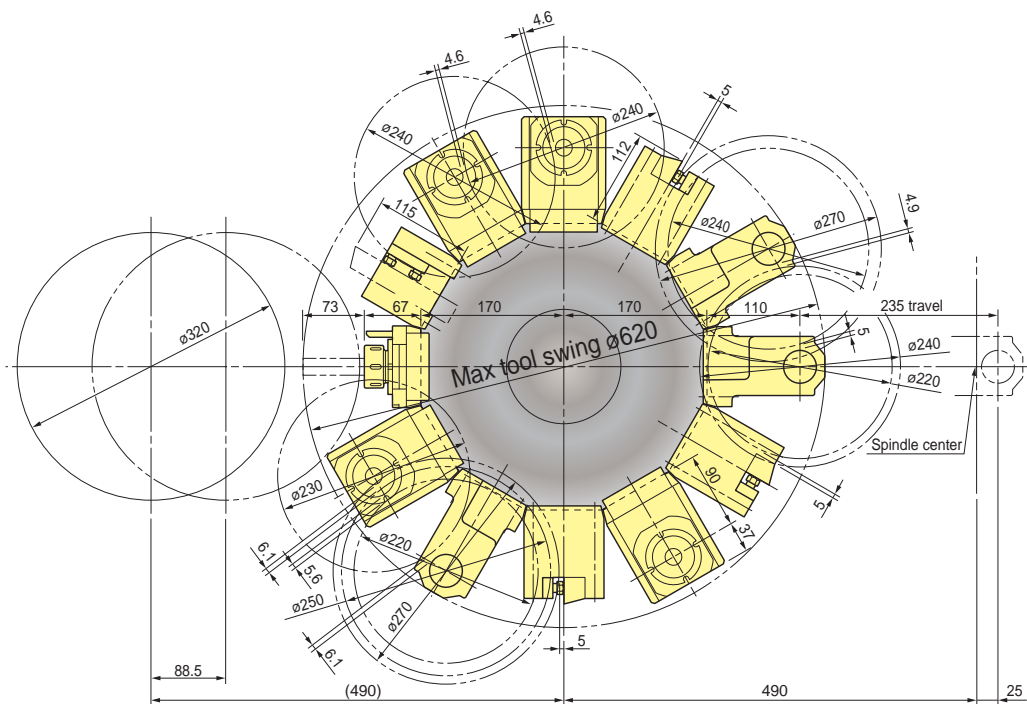
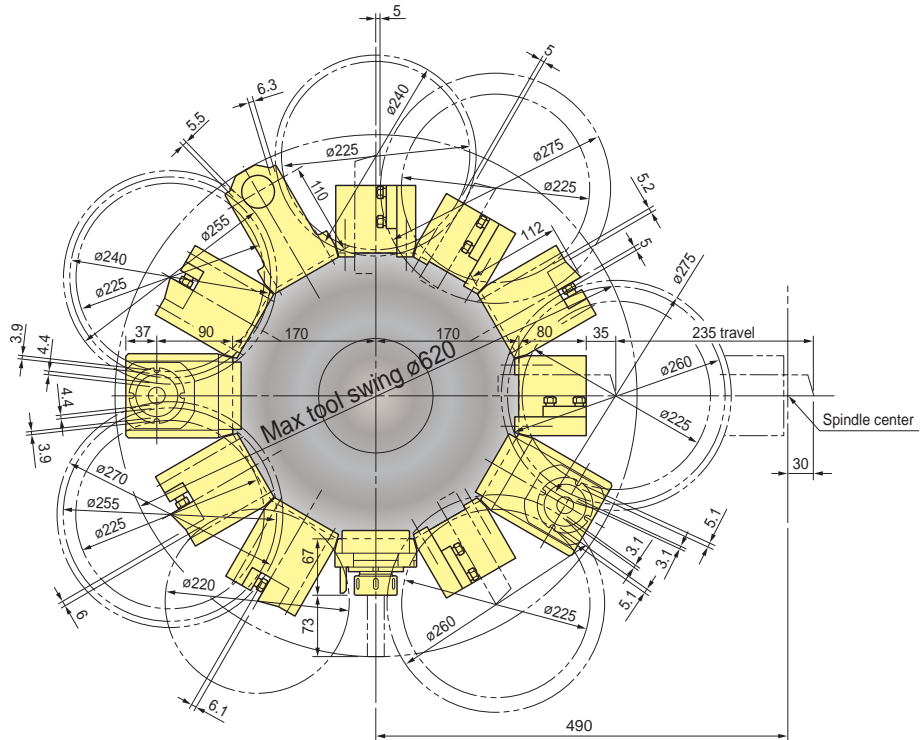

メモ

A large rectangular area containing 21 horizontal lines for writing notes.



メモ

SUHNER®

EXPERTS. SINCE 1914.



ABRASIVE









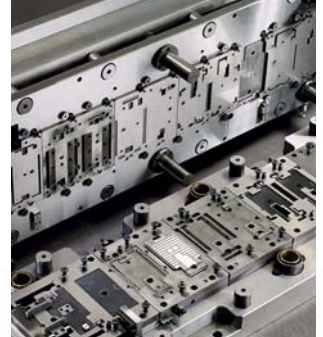







MACHINING



TRANSMISSION



STAMPING

					
	Switzerland	OTTO SUHNER AG	Lupfig	machining.ch@suhner.com	+41 (0)56 464 28 28
	Switzerland	SUHNER Automation AG	Lupfig	machining.sag@suhner.com	+41 (0)56 464 28 45
	Switzerland	SU-matic AG	Lupfig	machining.su-matic@suhner.com	+41 (0)56 464 29 90
	Germany	Otto Suhner GmbH	Bad Säckingen	machining.de@suhner.com	+49 (0)7761 557 0
	Austria	SUHNER SU-matic	Wien	machining.at@suhner.com	+43 (0)1 587 16 14
	USA	SUHNER Industrial Products Corp.	Rome, GA	machining.us@suhner.com	+1 (706) 235-8046
	France	Somex SAS	Ensisheim	machining.fr@suhner.com	+33 (0)3 89 81 12 12
	Italy	Suhner SU-matic S.r.l.	Zola Predosa	machining.it@suhner.com	+39 051 6 16 66 73
	Mexico	SUHNER Productos Industriales	San Juan del Rio	machining.mx@suhner.com	+52 427 272 39 78
	India	SUHNER India Pvt. Ltd.	Bangalore	machining.in@suhner.com	+91 (0) 80- 27 831108
	China	Suhner (Suzhou) Ind. Techn. Ltd.	Suzhou	machining.cn@suhner.com	+86 512 628 77 808

www.suhner.com