

SUHNER[®]
MACHINING

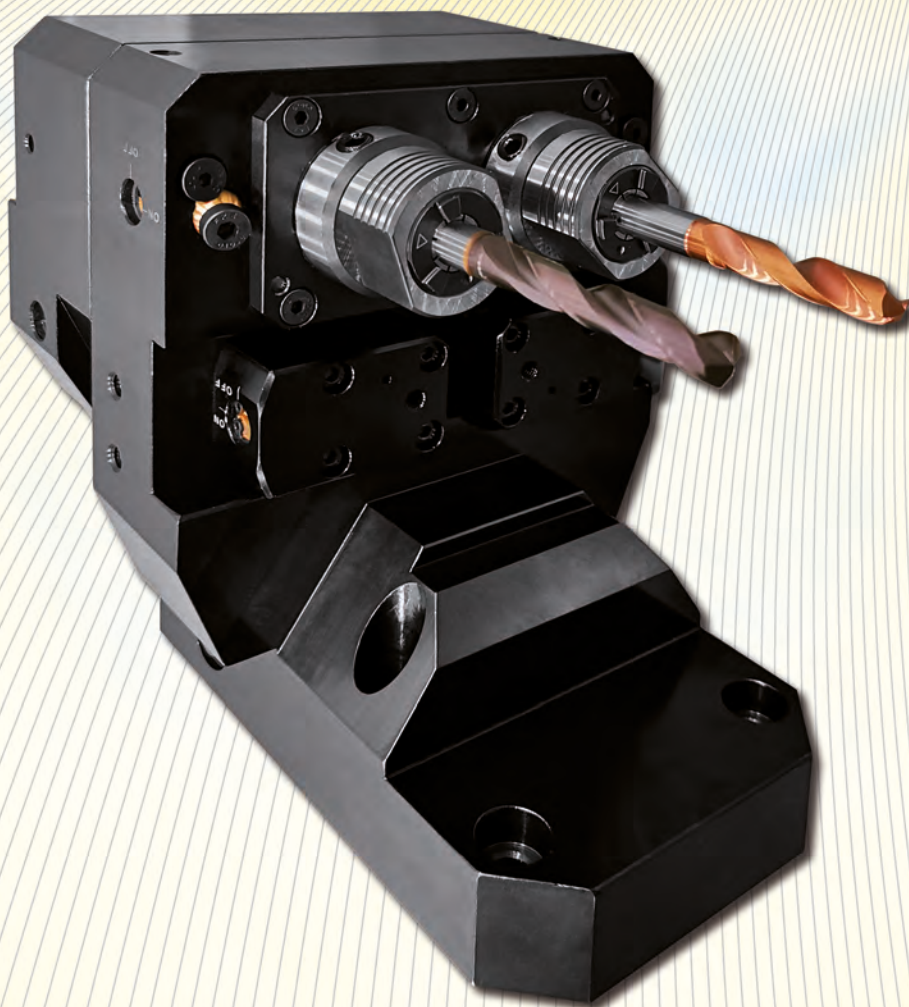

ツールホルダー
TSUGAMI

B038T 用



SUHNER[®]
EXPERTS. SINCE 1914.



シューマチック社について

貴方の機械の加工能力を増強します。。。







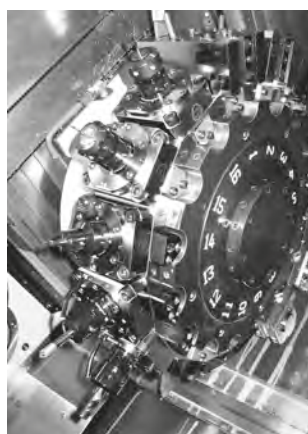



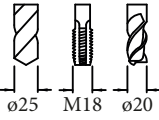

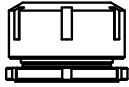
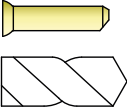
大きな投資をしなくても。。。

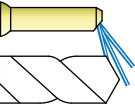
弊社では多軸ヘッド、アングルおよびリボルバーヘッドなど全ての種類のツールホルダーを製造し有名工作機械メーカー殿やOEMメーカーに供給しています。高い性能の装置はDIN規格に準拠し、お客様ご指定のインターフェースに適合しています。標準化された製品の供給は世界的なブランドであるAのアルフレッドシュッテ (ALFRED SCHUTTE,) からWのワールドリッヒ。コブルグ(WALDRICH COBURG)まで拡張しています。

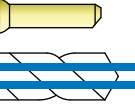

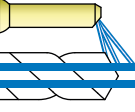



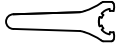









機械メーカーとの新しい製品開発の連携は非常に速い段階から始まります。従って新しい機械が発表された時点で既に実用的な準備はできています。我々は計画、製造、品質管理そしてサービスの全てを自社で行っております。親会社であるスナー(SUHNER)社の世界的な展開により、大きな恩恵を受けています。



記号の意味

	品名		品名
	これら3つのシンボルはこのユニットで使用可能な最大切削工具径を示しています (ドリル、タップ、ミーリングカッター)。	#	ユニットび部品番号
	内部クーラント型の場合には絶対にドライでは使用しないで下さい。		スピンドル出力インターフェース
	クーラントは使用できません		クーラントタイプ
	外部クーラント		ターニング方向 入力:出力
	内部クーラント		減速比 入力:出力
	内部及び外部クーラント		出力側の最大回転数 (RPM)
	このユニットはオイルミスト潤滑が必要です		出力側の最大トルク
	本キャプトユニットはサンドビックコロマントの認定を受けています (ISO26623-2)。	# 	特別付属のレンチの部品番号

ライブツール(回転工具)

	#			i $n_1 : n_2$	$n_{2 \max}$	$T_{2 \max}$	在庫品*	ページ
	14101003820S	QC ø30		2 : 1	2'000 min ⁻¹	40 Nm	受注生産	5
	14101003810S	QC ø20		1 : 1.5	6'000 min ⁻¹	25 Nm	受注生産	5
	14101003800S	QC ø20		1 : 3	12'000 min ⁻¹	8 Nm	受注生産	5
	14801001530S	QC ø20		1 : 3	12'000 min ⁻¹	5 Nm	受注生産	6
	14801001540S	QC ø20		1 : 3	12'000 min ⁻¹	5 Nm	受注生産	6
	14801001480S	QC ø20		1 : 3	12'000 min ⁻¹	5 Nm	受注生産	7
	14801001550S	ER 11		1 : 3	12'000 min ⁻¹	5 Nm	受注生産	7
	14826000380S	ERAX 16		1 : 1	6'000 min ⁻¹	14 Nm	受注生産	8

付属品

	品名		在庫品*	ページ
	高圧クーラントパイプ	-	受注生産	9
	Quick Change Holder	ER 11 - ER 25	受注生産	9
	コレット	ER 11 - ER 50	受注生産	10

ライブツール(回転工具)

TSUGAMI

Lathe Linear Unit Offset • LLUO 40-1 R

Machine Types

B038T

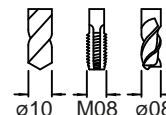
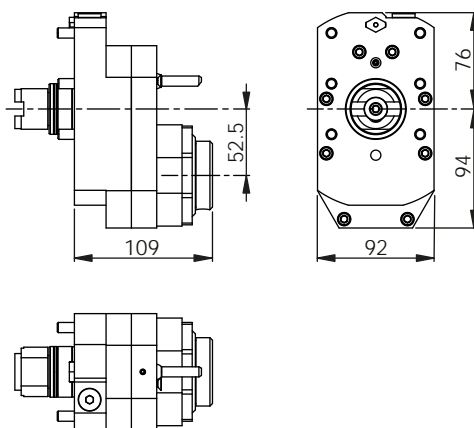
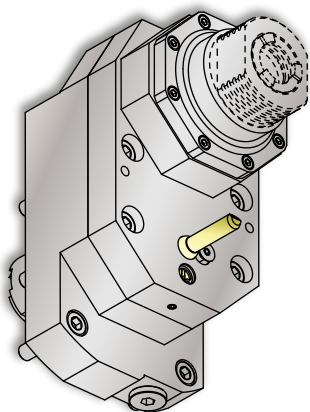

#			$n_1 : n_2$	$i : n_2$	$n_2 \text{ max}$	$T_2 \text{ max}$	#
14101003820S	QC ø30	100 bar		2 : 1	2'000 min ⁻¹	40 Nm	-

Lathe Linear Unit Offset • LLUO 25-2 R • LLUO 8-2 R

Machine Types

B038T

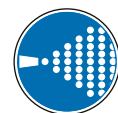
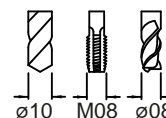
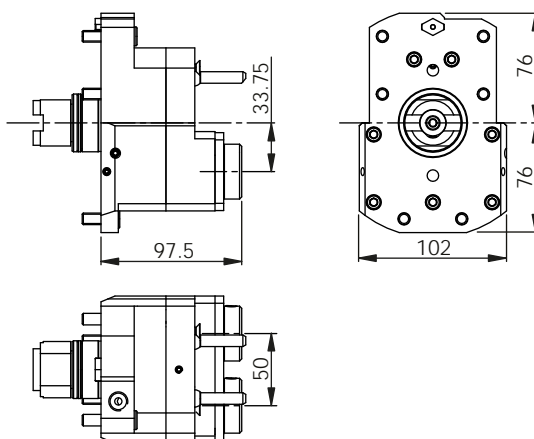
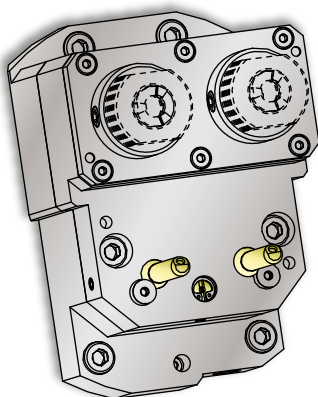

14101003800

#			$n_1 : n_2$	$i : n_2$	$n_2 \text{ max}$	$T_2 \text{ max}$	#
14101003810S	QC ø20	100 bar		1 : 1.5	6'000 min ⁻¹	25 Nm	-
14101003800S	QC ø20	100 bar		1 : 3	12'000 min ⁻¹	8 Nm	-

ライブツール(回転工具)

TSUGAMI

Lathe Angular Unit Offset • LAUO 5-2 A

Machine Types B038T

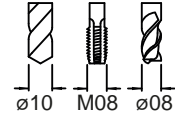
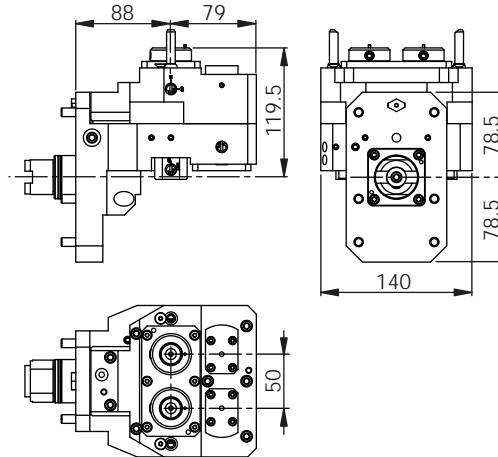
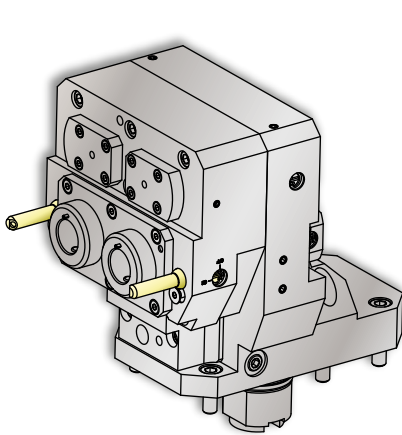

準備中

#			$n_1 : n_2$	i $n_1 : n_2$	$n_2 \text{ max}$	$T_2 \text{ max}$	#
14801001530S	QC ø20	100 bar		1 : 3	12'000 min ⁻¹	5 Nm	-

Lathe Angular Unit Offset • LAUO 5-2 A

Machine Types B038T

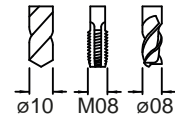
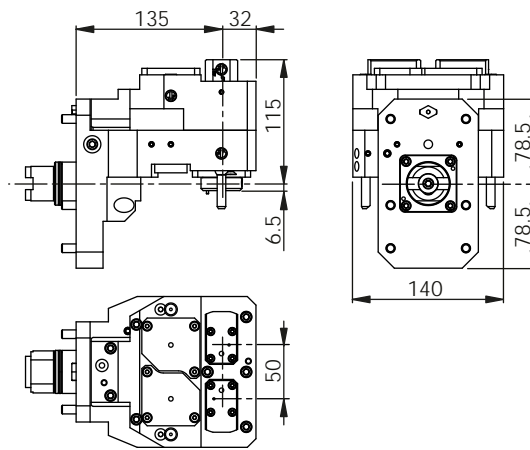
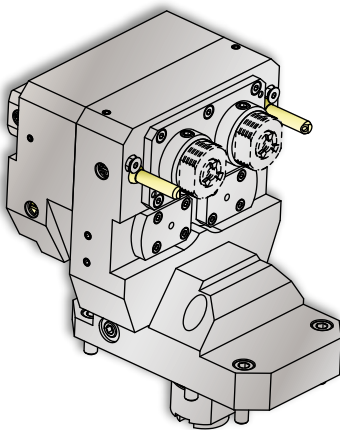







準備中

#			$n_1 : n_2$	i $n_1 : n_2$	$n_2 \text{ max}$	$T_2 \text{ max}$	#
14801001540S	QC ø20	100 bar		1 : 3	12'000 min ⁻¹	5 Nm	-

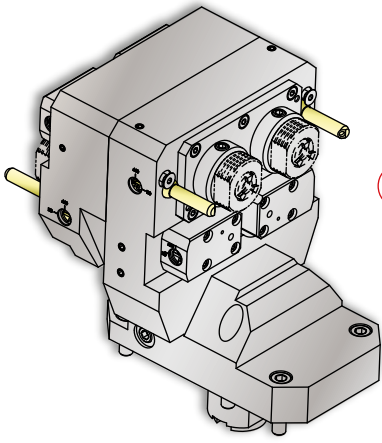
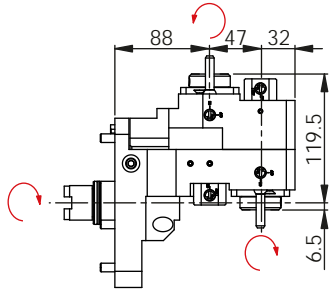
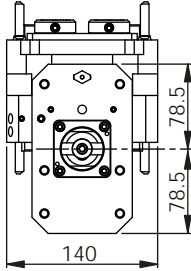
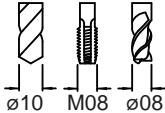



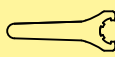

ライブツール(回転工具)

TSUGAMI

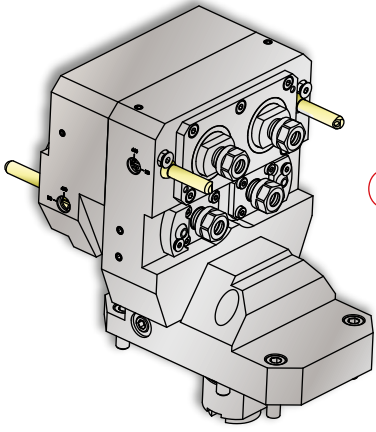
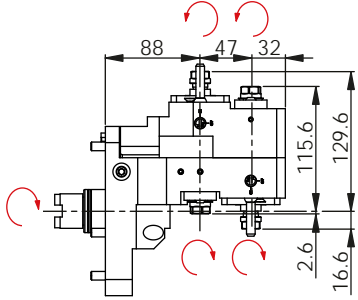
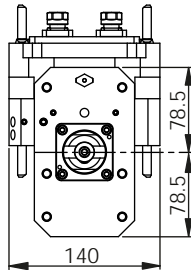
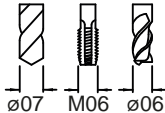
Lathe Angular Unit Offset Twin • LAUOT 5-2+2 A

Machine Types	B038T							
								
#			$n_1 : n_2$	i $n_1 : n_2$	$n_{2 \max}$	$T_{2 \max}$	# 	
14801001480S	QC ø20	 100 bar	-	1 : 3	12'000 min ⁻¹	5 Nm	-	

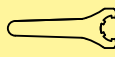
Lathe Angular Unit Offset Twin • LAUOT 5-4+4 A

Machine Types	B038T							
								
#			$n_1 : n_2$	i $n_1 : n_2$	$n_{2 \max}$	$T_{2 \max}$	# 	
14801001550S	ER 11	 100 bar	-	1 : 3	12'000 min ⁻¹	5 Nm	-	

準備中

ライブツール(回転工具)

TSUGAMI

Lathe Angular Unit Adjustable • LAUA 14-1 A/R

Machine
Types

B038T

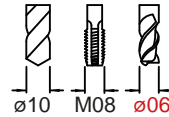
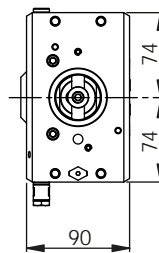
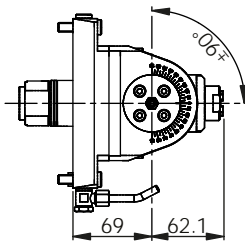
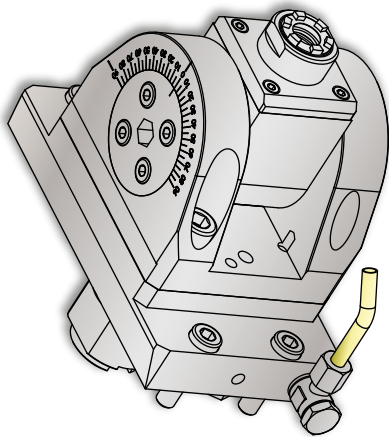

#			$n_1 : n_2$	i $n_1 : n_2$	$n_{2 \max}$	$T_{2 \max}$	#
14826000380S	ERAX 16	100 bar		1 : 1	6'000 min ⁻¹	14 Nm	-

付属品

TSUGAMI

高圧クーラントパイプ

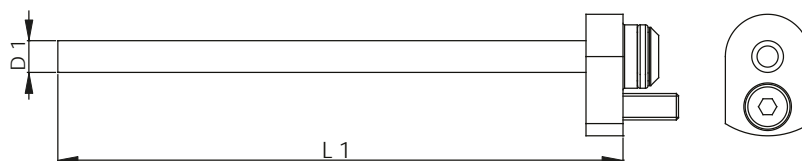
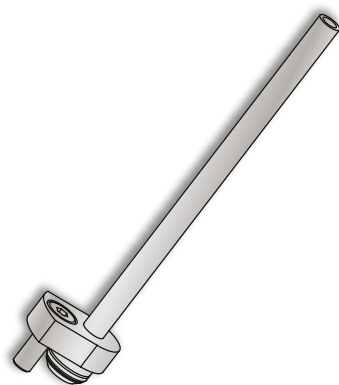

#	L1	D1
14430000750	107	6

Quick Change Tool Holder

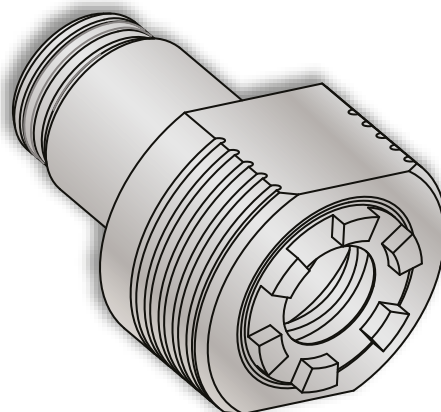

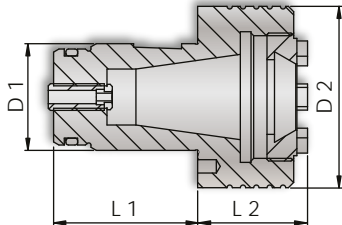
Quick Change	#		D1	D2	L1	L2
	14420001850	ERAX 11	QC ø20	34	27	15.2
	14420001860	ERAX 16	QC ø20	34	27	20.6
	14420001840	ERAX 25	QC ø30	49	38	21.9

付属品

TSUGAMI

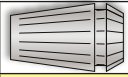

SU-matic コレット

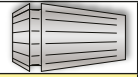

	ER 11	ER 16	ER 20	ER 25	ER 32	ER 40	ER 50
ø 1.00 - 0.50	3900110010	3900160010	3900200010	3900250010	-	-	-
ø 2.00 - 1.00	3900110020	3900160020	3900200020	3900250020	3900320020	-	-
ø 3.00 - 2.00	3900110030	3900160030	3900200030	3900250030	3900320030	3900400030	-
ø 4.00 - 3.00	3900110040	3900160040	3900200040	3900250040	3900320040	3900400040	-
ø 5.00 - 4.00	3900110050	3900160050	3900200050	3900250050	3900320050	3900400050	3900500060
ø 6.00 - 5.00	3900110060	3900160060	3900200060	3900250060	3900320060	3900400060	3900500060
ø 7.00 - 6.00	3900110070	3900160070	3900200070	3900250070	3900320070	3900400070	3900500080
ø 8.00 - 7.00	-	3900160080	3900200080	3900250080	3900320080	3900400080	3900500080
ø 9.00 - 8.00	-	3900160090	3900200090	3900250090	3900320090	3900400090	3900500100
ø 10.00 - 9.00	-	3900160100	3900200100	3900250100	3900320100	3900400100	3900500100
ø 11.00 - 10.00	-	-	3900200110	3900250110	3900320110	3900400110	3900500120
ø 12.00 - 11.00	-	-	3900200120	3900250120	3900320120	3900400120	3900500120
ø 13.00 - 12.00	-	-	3900200130	3900250130	3900320130	3900400130	3900500140
ø 14.00 - 13.00	-	-	-	3900250140	3900320140	3900400140	3900500140
ø 15.00 - 14.00	-	-	-	3900250150	3900320150	3900400150	3900500160
ø 16.00 - 15.00	-	-	-	3900250160	3900320160	3900400160	3900500160
ø 17.00 - 16.00	-	-	-	3900250170	3900320170	3900400170	3900500180
ø 18.00 - 17.00	-	-	-	-	3900320180	3900400180	3900500180
ø 19.00 - 18.00	-	-	-	-	3900320190	3900400190	3900500200
ø 20.00 - 19.00	-	-	-	-	3900320200	3900400200	3900500200
ø 21.00 - 20.00	-	-	-	-	3900320210	3900400210	3900500220
ø 22.00 - 21.00	-	-	-	-	3900320220	3900400220	3900500220
ø 23.00 - 22.00	-	-	-	-	-	3900400230	3900500240
ø 24.00 - 23.00	-	-	-	-	-	3900400240	3900500240
ø 25.00 - 24.00	-	-	-	-	-	3900400250	3900500260
ø 26.00 - 25.00	-	-	-	-	-	3900400260	3900500260
ø 27.00 - 26.00	-	-	-	-	-	3900400270	3900500280
ø 28.00 - 27.00	-	-	-	-	-	3900400280	3900500280
ø 29.00 - 28.00	-	-	-	-	-	3900400290	3900500300
ø 30.00 - 29.00	-	-	-	-	-	3900400300	3900500300
ø 32.00 - 30.00	-	-	-	-	-	-	3900500320
ø 34.00 - 32.00	-	-	-	-	-	-	3900500340
ø 36.00 - 34.00	-	-	-	-	-	-	3900500360

SUHNER®

EXPERTS. SINCE 1914.



ABRASIVE

















MACHINING



TRANSMISSION



STAMPING

				
	Switzerland			
	Switzerland			
	Germany			
	Austria			
	USA			
	France			
	Italy			
	Mexico			
	India			
	China			
	OTTO SUHNER AG	Lupfig	machining.ch@suhner.com	+41 (0)56 464 28 28
	SU-matic AG	Lupfig	machining.su-matic@suhner.com	+41 (0)56 464 29 90
	Otto Suhner GmbH	Bad Säckingen	machining.de@suhner.com	+49 (0)7761 557 0
	SUHNER SU-matic	Wien	machining.at@suhner.com	+43 (0)1 587 16 14
	SUHNER Industrial Products Corp.	Rome, GA	machining.us@suhner.com	+1 (706) 235-8046
	Somex SAS	Ensisheim	machining.fr@suhner.com	+33 (0)3 89 81 12 12
	Suhner SU-matic S.r.l.	Zola Predosa	machining.it@suhner.com	+39 051 6 16 66 73
	SUHNER Productos Industriales	San Juan del Rio	machining.mx@suhner.com	+52 427 272 39 78
	SUHNER India Pvt. Ltd.	Bangalore	machining.in@suhner.com	+91 (0) 80- 27 831108
	Suhner (Suzhou) Ind. Techn. Ltd.	Suzhou	machining.cn@suhner.com	+86 512 628 77 808

www.suhner.com